

**POLFLAM**<sup>®</sup>  
FIRE RESISTANT GLASS



# FIRE-RESISTANT GLASS IN TIMBER STRUCTURES

October 2021

I POLFLAM is an independent manufacturer of fire protection glass: beginning with technology through research – down to production. I POLFLAM fire protection glass is made in modern hydrogel technology. It allows you to obtain glass of exceptional functionality.

On the European market, I POLFLAM brand is today an unquestionable synonym of product quality.

### Colours available



### Glass variants



- large glass sheets
- glass sheets of non-standard shapes
- bent fire-resistant glass in each EI class
- high acoustic insulation  $R_w$
- high light transmittance factor  $L_t$
- UV radiation resistance – no need of PVB film
- highest safety class 1/B/1 (acc. PN-EN 12600)
- resistance to temperatures from  $-40^{\circ}\text{C}$  to  $+50^{\circ}\text{C}$
- symmetrical design
- fitting-friendly glass (blunted edges, no need of positioning)
- high water resistance (no need of protecting glass edges)
- high impact resistance – toughened glass
- lower weight than multi-layered fire-resistant glass
- possibility to combine with most float glass of high thermal properties available in the market (solar control, light transmittance, thermal insulation) = improved building's energy balance

POLFLAM® fire-resistant glass is tested in certified research institutes across Europe.



With a fire resistance test furnace installed at our production facility POLFLAM® can test new solutions in accordance with European standards.



## POLFLAM glass in timber structures

POLFLAM glass is installed in traditional timber joinery systems. It can be used both outdoors and indoors. In the timber, POLFLAM glass panels of various geometric shapes (arched, triangles, etc.) are installed.

| POLFLAM glass               | EI 15                       | EW 30 | EI 30 | EW 60 | EI 60 |      | EI 90 |      | EI 120* | EI 180* |
|-----------------------------|-----------------------------|-------|-------|-------|-------|------|-------|------|---------|---------|
| Thickness [mm]              | 16                          | 16    | 20    | 20    | 25    | 28   | 32    | 35   | 35      | 55      |
| Weight [kg/m <sup>2</sup> ] | 33                          | 33    | 38    | 38    | 45    | 49   | 52    | 57   | 57      | 83      |
| Light transmittance [Lt%]   | 86,0                        | 86,0  | 87,6  | 87,6  | 87,1  | 87,0 | 85,8  | 87,0 | 85,5    | 85,3    |
| Sound reduction Rw [dB]     | 41                          | 41    | 42    | 42    | 44    | 45   | 44    | 47   | 45      | 45      |
| Safety class                | 1/B/1 (acc. to PN-EN 12600) |       |       |       |       |      |       |      |         |         |
| Operating temperature range | -40°C / +50°C               |       |       |       |       |      |       |      |         |         |
| Bent glass                  | yes                         |       |       |       |       |      |       |      |         |         |

\* Tests for resistance to fire are possible to conduct.

*This brochure gives a brief overview of the possibilities for POLFLAM fire resistant glass in timber systems. For the correct installation details and instructions the classification or test report from the tested construction should be consulted.*

*Please contact your local POLFLAM specialist for more information*

# LIST OF PRODUCTS

## POLFLAM glass in timber structures

| Product           | Fire resistance class | Min. thickness glass | Max. glass dimensions - portrait [mm] (max. surface area) | Max. glass dimensions - landscape [mm] (max. surface area) | System         | Page  |
|-------------------|-----------------------|----------------------|---|--|----------------|-------|
| POLFLAM EI 15     | EI 15                 | 16 mm                | 1500 x 3000 ( $A_{max} = 4,5 \text{ m}^2$ )               | 2310 x 1500 ( $A_{max} = 3,47 \text{ m}^2$ )               | Partition wall | 5     |
| POLFLAM EI 15 DGU | EI 15                 | 16/18 mm             | 1800 x 3600 ( $A_{max} = 5,45 \text{ m}^2$ )              | 2772 x 1800 ( $A_{max} = 4,20 \text{ m}^2$ )               | Partition wall | 6     |
| POLFLAM EI 15 TGU | EI 15                 | 16/18 mm             | 1800 x 3600 ( $A_{max} = 5,45 \text{ m}^2$ )              | 2772 x 1800 ( $A_{max} = 4,20 \text{ m}^2$ )               | Partition wall | 7     |
| POLFLAM EW 30     | EW 30                 | 16/18 mm             | 1650 x 3300 ( $A_{max} = 4,95 \text{ m}^2$ )              | 2541 x 1650 ( $A_{max} = 3,81 \text{ m}^2$ )               | Partition wall | 8     |
| POLFLAM EW 30 DGU | EW 30                 | 16 mm                | 1500 x 3000 ( $A_{max} = 4,5 \text{ m}^2$ )               | 2310 x 1500 ( $A_{max} = 3,47 \text{ m}^2$ )               | Partition wall | 9     |
| POLFLAM EW 30 TGU | EW 30                 | 16 mm                | 1500 x 3000 ( $A_{max} = 4,5 \text{ m}^2$ )               | 2310 x 1500 ( $A_{max} = 3,47 \text{ m}^2$ )               | Partition wall | 10    |
| POLFLAM EI 30     | EI 30                 | 20/22 mm             | 1800 x 4200 ( $A_{max} = 6,35 \text{ m}^2$ )              | 3600 x 1800 ( $A_{max} = 5,45 \text{ m}^2$ )               | Partition wall | 11    |
| POLFLAM EI 30 DGU | EI 30                 | 20/22 mm             | 1800 x 4200 ( $A_{max} = 6,35 \text{ m}^2$ )              | 3600 x 1800 ( $A_{max} = 5,45 \text{ m}^2$ )               | Partition wall | 12    |
| POLFLAM EI 30 TGU | EI 30                 | 20/22 mm             | 1800 x 4200 ( $A_{max} = 6,35 \text{ m}^2$ )              | 3600 x 1800 ( $A_{max} = 5,45 \text{ m}^2$ )               | Partition wall | 13    |
| POLFLAM EI 30     | EI 30                 | 20 mm                | 1500 x 3000 ( $A_{max} = 4,5 \text{ m}^2$ )               | 1500 x 3000 ( $A_{max} = 4,5 \text{ m}^2$ )                | Partition wall | 14    |
| POLFLAM EI 30     | EI 30                 | 20 mm                | 658 x 1638  | 658 x 1638   | Door           | 15    |
| POLFLAM EI 45     | EI 45                 | 25 mm                | 907 x 1980  | 907 x 1980   | Door           | 16    |
| POLFLAM EW 60     | EW 60                 | 20 mm                | 1500 x 3000 ( $A_{max} = 4,5 \text{ m}^2$ )               | 2310 x 1500 ( $A_{max} = 3,47 \text{ m}^2$ )               | Partition wall | 17    |
| POLFLAM EI 60     | EI 60                 | 25 mm                | 1090 x 2290   | 1090 x 2290  | Partition wall | 18    |
| POLFLAM EI 60 DGU | EI 60                 | 25 mm                | 1526 x 1828   | 1526 x 1828  | Partition wall | 19    |
| POLFLAM EI 60     | EI 60                 | 28 mm                | 1500 x 3000 ( $A_{max} = 4,5 \text{ m}^2$ )               | 1500 x 3000 ( $A_{max} = 4,5 \text{ m}^2$ )                | Partition wall | 20    |
| POLFLAM EI 60     | EI 60                 | 28/30 mm             | 1800 x 4200 ( $A_{max} = 6,35 \text{ m}^2$ )              | 3600 x 1800 ( $A_{max} = 5,45 \text{ m}^2$ )               | Partition wall | 21    |
| POLFLAM EI 60 DGU | EI 60                 | 28/30 mm             | 1800 x 4200 ( $A_{max} = 6,35 \text{ m}^2$ )              | 3600 x 1800 ( $A_{max} = 5,45 \text{ m}^2$ )               | Partition wall | 22    |
| POLFLAM EI 60 TGU | EI 60                 | 28/30 mm             | 1800 x 4200 ( $A_{max} = 6,35 \text{ m}^2$ )              | 3600 x 1800 ( $A_{max} = 5,45 \text{ m}^2$ )               | Partition wall | 23    |
| POLFLAM EI 90     | EI 90                 | 32 mm                | 270 x 1625  | –  | Partition wall | 24    |
| POLFLAM EI 90     | EI 90                 | 34 mm                | 2150 x 3300   | –  | Partition wall | 25    |
| POLFLAM EI 90     | EI 90                 | 35/37 mm             | 2400 x 4200 ( $A_{max} = 8,47 \text{ m}^2$ )              | 3600 x 1800 ( $A_{max} = 5,45 \text{ m}^2$ )               | Partition wall | 26    |
| POLFLAM EI 90 DGU | EI 90                 | 35/37 mm             | 1800 x 4200 ( $A_{max} = 6,35 \text{ m}^2$ )              | 3600 x 1800 ( $A_{max} = 5,45 \text{ m}^2$ )               | Partition wall | 27    |
| POLFLAM EI 90 TGU | EI 90                 | 35/37 mm             | 1800 x 4200 ( $A_{max} = 6,35 \text{ m}^2$ )              | 3600 x 1800 ( $A_{max} = 5,45 \text{ m}^2$ )               | Partition wall | 28    |
| POLFLAM BR EI 30  | EI 30                 | 30 mm                | 2400 x 4200 ( $A_{max} = 8,47 \text{ m}^2$ )              | 2400 x 4200 ( $A_{max} = 8,47 \text{ m}^2$ )               | Partition wall | 30    |
| POLFLAM BR EI 30  | EI 30                 | 30 mm                | 2200 x 4200   | 2200 x 4200  | Partition wall | 31-33 |
| POLFLAM BR EI 60  | EI 60                 | 38 mm                | 2200 x 4200 ( $A_{max} = 8,47 \text{ m}^2$ )              | 2200 x 4200 ( $A_{max} = 8,47 \text{ m}^2$ )               | Partition wall | 34    |
| POLFLAM BR EI 60  | EI 60                 | 35 mm                | 2200 x 3850 ( $A_{max} = 7,70 \text{ m}^2$ )              | 2200 x 3850 ( $A_{max} = 7,70 \text{ m}^2$ )               | Partition wall | 35-37 |
| POLFLAM BR EI 90  | EI 90                 | 45 mm                | 2200 x 4200 ( $A_{max} = 8,47 \text{ m}^2$ )              | 2200 x 4200 ( $A_{max} = 8,47 \text{ m}^2$ )               | Partition wall | 38    |



# POLFLAM EI 15

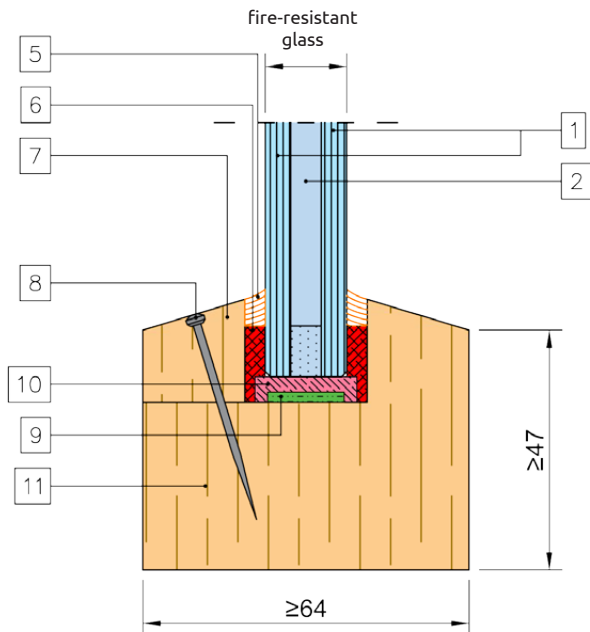
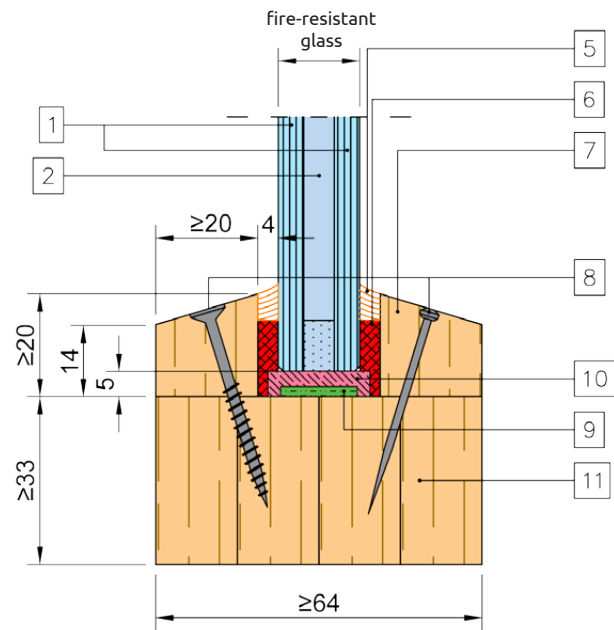

## Installation of POLFLAM glass in timber structures

| POLFLAM EI 15 (16 mm)                        |  |
|--|--|
| Partition wall                               |  |
| max. glass dimensions                        | 1500 mm x 3000 mm ( $A_{max} = 4,5 \text{ m}^2$ ) - portrait   |
|  | 2310 mm x 1500 mm ( $A_{max} = 3,47 \text{ m}^2$ ) - landscape |
| reference document: Test Report LBO-058-N/20 |  |

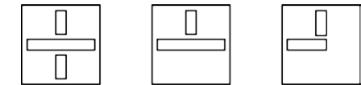

|    |   |
|----|---|
| 1  | thermally toughened glass $\geq 5 \text{ mm}$ thickness<br>thermally toughened patterned glass $\geq 6 \text{ mm}$ thickness<br>(individual panes can be tinted, coated, surface treated) |
| 2  | hydrogel interlayer $\geq 6 \text{ mm}$ thickness   |
| 5  | silicon Dowsil 791  |
| 6  | ceramic tape KERAFIX 2000 15 x 4 mm   |
| 7  | glazing bead $\geq 20 \text{ mm} \times 20/14 \text{ mm}$ , timber $\geq 560 \text{ kg/m}^3$  |
| 8  | nail min. 16GA x 40 mm or screw $\varnothing 3,5 \times 40 \text{ mm}$<br>(20-40 mm from the corner and every 200 mm)   |
| 9  | intumescent tape KERAFIX FXL200 20 x 2 mm   |
| 10 | supporting block 5 mm   |
| 11 | laminated or solid timber $\geq 560 \text{ kg/m}^3$   |

### Allowed supported construction

rigid supporting construction min.  $600 \text{ kg/m}^3$ ; min. 115 mm thickness

# POLFLAM EI 15 DGU

## Installation of POLFLAM glass in timber structures

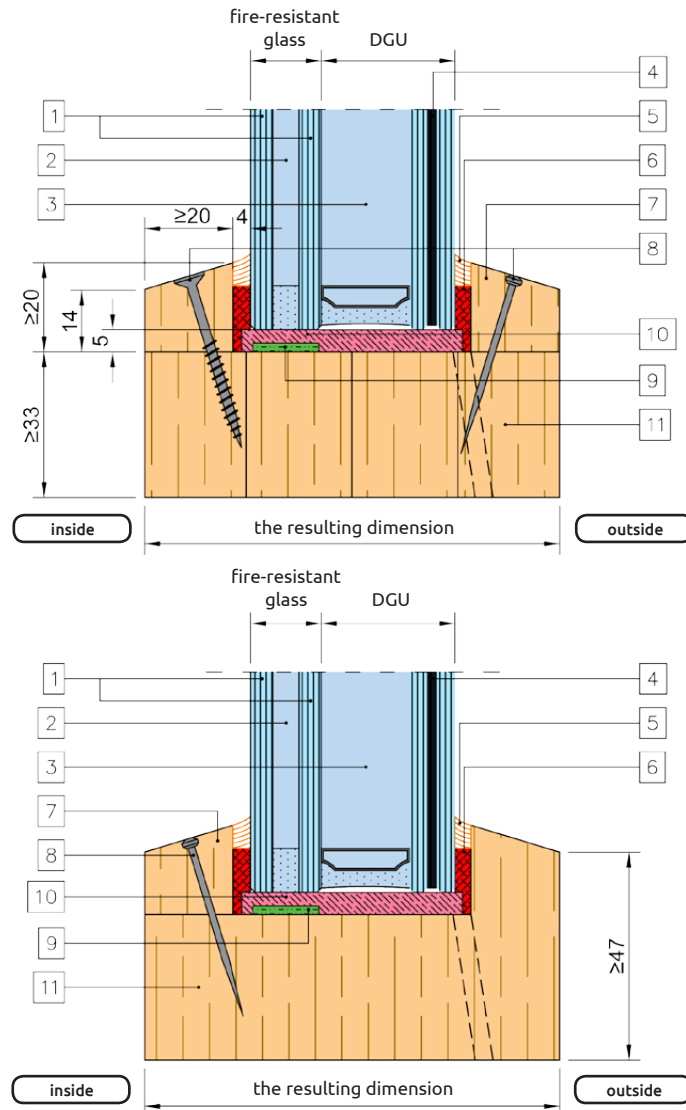

### POLFLAM EI 15 (16/18 mm) DGU

#### Partition wall

|   |   |
|---|---|
| <b>max. glass dimensions</b>                | 1800 mm x 3600 mm ( $A_{\max} = 5,45 \text{ m}^2$ ) - portrait  |
|   | 2772 mm x 1800 mm ( $A_{\max} = 4,20 \text{ m}^2$ ) - landscape |
| reference document: Test Report LBO-1525/21 |   |

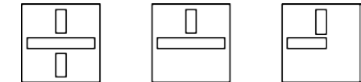

|           |   |
|-----------|---|
| <b>1*</b> | thermally toughened glass $\geq 5$ mm thickness<br>thermally toughened patterned glass $\geq 6$ mm thickness<br>(individual panes can be tinted, coated, surface treated) |
| <b>2</b>  | hydrogel interlayer $\geq 6$ mm thickness   |
| <b>3</b>  | spacer $8 \div 20$ mm thickness   |
| <b>4</b>  | glass $\geq 4$ mm thickness:<br>- float;<br>- thermally toughened glass (ESG);<br>- laminated glass (VSG);<br>(individual panes can be tinted, coated, surface treated)   |
| <b>5</b>  | silicon Dowsil 791  |
| <b>6</b>  | ceramic tape KERAFIX 2000 15 x 4 mm   |
| <b>7</b>  | glazing bead $\geq 20$ mm x 20/14 mm, timber $\geq 560 \text{ kg/m}^3$  |
| <b>8</b>  | nail min. 16GA x 40 mm or screw $\varnothing 3,5$ x 40 mm<br>(20-40 mm from the corner and every 200 mm)  |
| <b>9</b>  | intumescent tape KERAFIX FXL200 20 x 2 mm   |
| <b>10</b> | supporting block 5 mm   |
| <b>11</b> | laminated or solid timber $\geq 560 \text{ kg/m}^3$   |

#### Allowed supported construction

rigid supporting construction min.  $600 \text{ kg/m}^3$ ; min. 115 mm thickness

\* above glass dimension over 1500 x 3000 mm or area over  $4,5 \text{ m}^2$   
glass pane pos. 1 – min. 6 mm thickness

# POLFLAM EI 15 TGU

## Installation of POLFLAM glass in timber structures

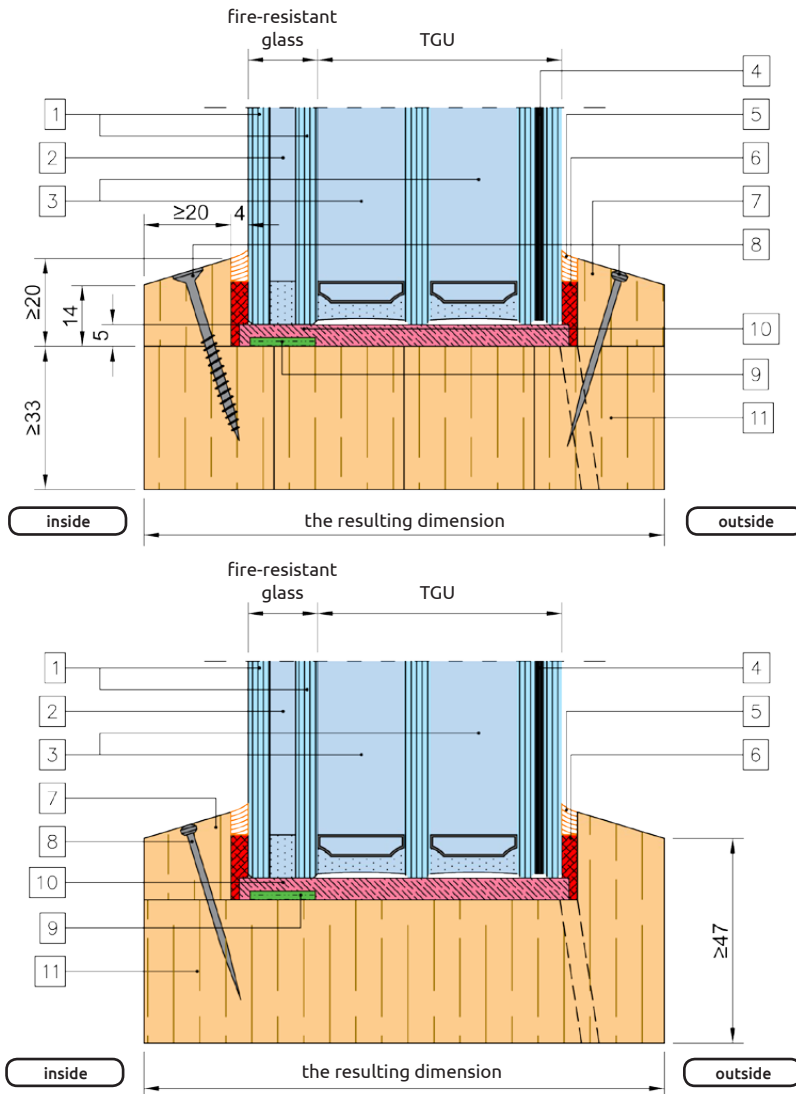

### POLFLAM EI 15 (16/18 mm) TGU

#### Partition wall

#### max. glass dimensions

1800 mm x 3600 mm ( $A_{max} = 5,45 \text{ m}^2$ ) - portrait

2772 mm x 1800 mm ( $A_{max} = 4,20 \text{ m}^2$ ) - landscape

reference document: Test Report LBO-1525/21

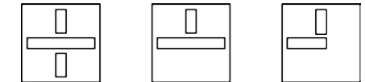

|    |   |
|----|---|
| 1* | thermally toughened glass $\geq 5 \text{ mm}$ thickness<br>thermally toughened patterned glass $\geq 6 \text{ mm}$ thickness<br>(individual panes can be tinted, coated, surface treated) |
| 2  | hydrogel interlayer $\geq 6 \text{ mm}$ thickness   |
| 3  | spacer $8 \div 20 \text{ mm}$ thickness   |
| 4  | glass $\geq 4 \text{ mm}$ thickness:<br>- float;<br>- thermally toughened glass (ESG);<br>- laminated glass (VSG);<br>(individual panes can be tinted, coated, surface treated)           |
| 5  | silicon Dowsil 791  |
| 6  | ceramic tape KERAFIX 2000 $15 \times 4 \text{ mm}$  |
| 7  | glazing bead $\geq 20 \text{ mm} \times 20/14 \text{ mm}$ , timber $\geq 560 \text{ kg/m}^3$  |
| 8  | nail min. 16GA x 40 mm or screw $\varnothing 3,5 \times 40 \text{ mm}$<br>(20-40 mm from the corner and every 200 mm)   |
| 9  | intumescent tape KERAFIX FXL200 $20 \times 2 \text{ mm}$  |
| 10 | supporting block $5 \text{ mm}$   |
| 11 | laminated or solid timber $\geq 560 \text{ kg/m}^3$   |

#### Allowed supported construction

rigid supporting construction min.  $600 \text{ kg/m}^3$ ; min.  $115 \text{ mm}$  thickness

\* above glass dimension over  $1500 \times 3000 \text{ mm}$  or area over  $4,5 \text{ m}^2$   
glass pane pos.1 – min.  $6 \text{ mm}$  thickness

# POLFLAM EW 30

## Installation of POLFLAM glass in timber structures

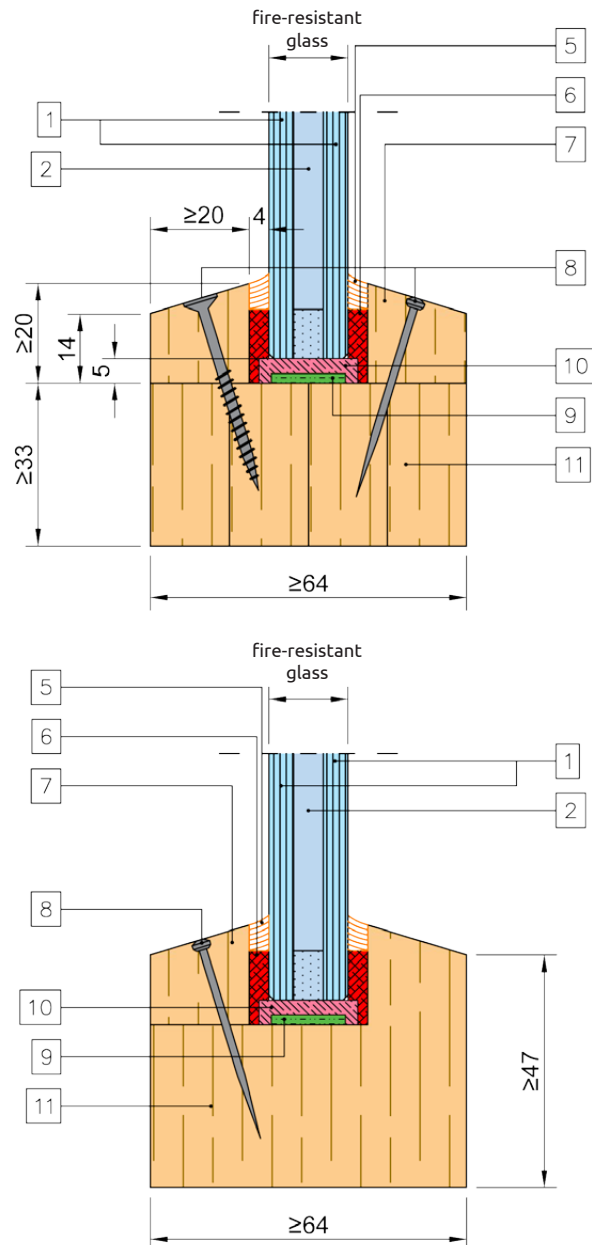

### POLFLAM EW 30 (16/18 mm)

#### Partition wall

|                              |  |
|------------------------------|--|
| <b>max. glass dimensions</b> | 1650 mm x 3300 mm ( $A_{max} = 4,95 \text{ m}^2$ ) - portrait  |
|                              | 2541 mm x 1650 mm ( $A_{max} = 3,81 \text{ m}^2$ ) - landscape |

reference document: Test report LBO-058-N/20

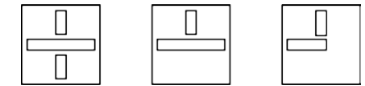

|           |   |
|-----------|---|
| <b>1*</b> | thermally toughened glass $\geq 5 \text{ mm}$ thickness<br>thermally toughened patterned glass $\geq 6 \text{ mm}$ thickness<br>(individual panes can be tinted, coated, surface treated) |
| <b>2</b>  | hydrogel interlayer $\geq 6 \text{ mm}$ thickness   |
| <b>5</b>  | silicon Dowsil 791  |
| <b>6</b>  | ceramic tape KERAFIX 2000 15 x 4 mm   |
| <b>7</b>  | glazing bead $\geq 20 \text{ mm} \times 20/14 \text{ mm}$ , timber $\geq 560 \text{ kg/m}^3$  |
| <b>8</b>  | nail min. 16GA x 40 mm or screw $\varnothing 3,5 \times 40 \text{ mm}$<br>(20-40 mm from the corner and every 200 mm)   |
| <b>9</b>  | intumescent tape KERAFIX FXL200 20 x 2 mm   |
| <b>10</b> | supporting block 5 mm   |
| <b>11</b> | laminated or solid timber $\geq 560 \text{ kg/m}^3$   |

#### Allowed supported construction

rigid supporting construction min.  $600 \text{ kg/m}^3$ ; min. 115 mm thickness

\* above glass dimension over 1500 x 3000 mm or area over  $4,5 \text{ m}^2$   
glass pane pos.1 – min. 6 mm thickness



# POLFLAM EW 30 DGU

## Installation of POLFLAM glass in timber structures

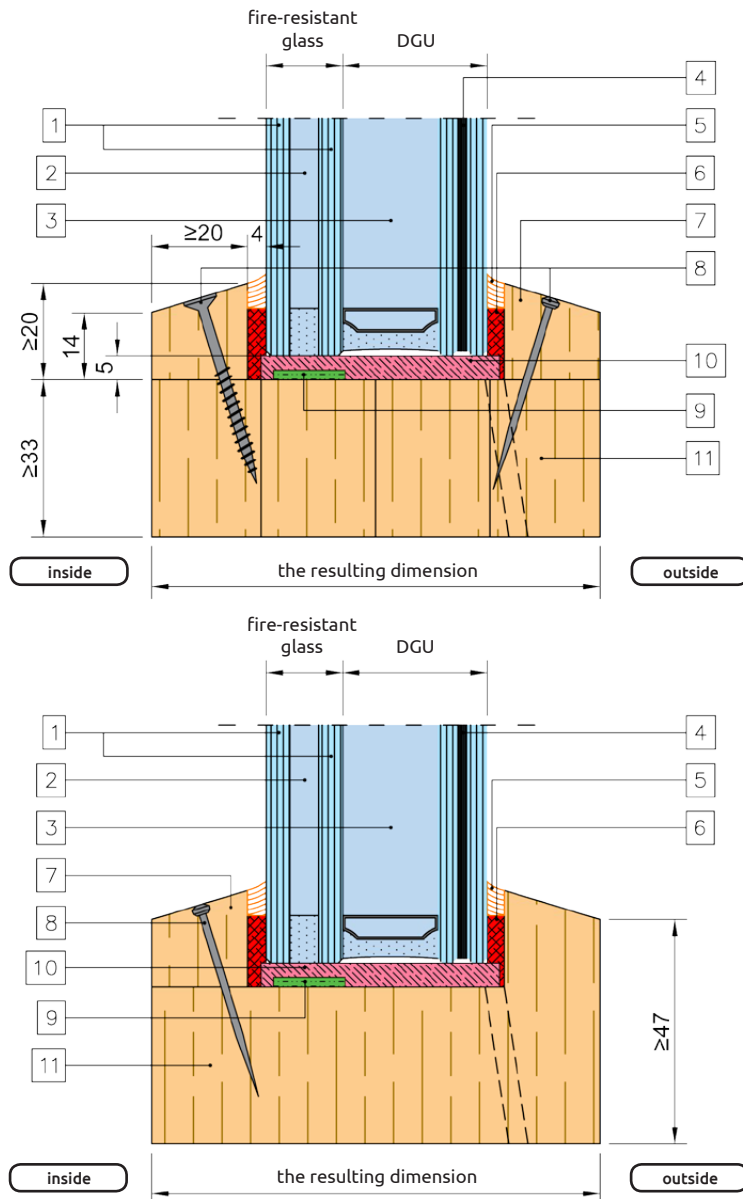

### POLFLAM EW 30 (16 mm) DGU

#### Partition wall

#### max. glass dimensions

1500 mm x 3000 mm ( $A_{max} = 4,5 \text{ m}^2$ ) - portrait

2310 mm x 1500 mm ( $A_{max} = 3,46 \text{ m}^2$ ) - landscape

reference document: Test report LBO-1525/21

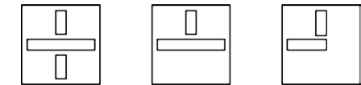

|    |   |
|----|---|
| 1  | thermally toughened glass $\geq 5$ mm thickness<br>thermally toughened patterned glass $\geq 6$ mm thickness<br>(individual panes can be tinted, coated, surface treated) |
| 2  | hydrogel interlayer $\geq 6$ mm thickness   |
| 3  | spacer $8 \div 20$ mm thickness   |
| 4  | glass $\geq 4$ mm thickness:<br>- float;<br>- thermally toughened glass (ESG);<br>- laminated glass (VSG);<br>(individual panes can be tinted, coated, surface treated)   |
| 5  | silicon Dowsil 791  |
| 6  | ceramic tape KERAFIX 2000 15 x 4 mm   |
| 7  | glazing bead $\geq 20$ mm x 20/14 mm, timber $\geq 560 \text{ kg/m}^3$  |
| 8  | nail min. 16GA x 40 mm or screw $\varnothing 3,5$ x 40 mm<br>(20-40 mm from the corner and every 200 mm)  |
| 9  | intumescent tape KERAFIX FXL200 20 x 2 mm   |
| 10 | supporting block 5 mm   |
| 11 | laminated or solid timber $\geq 560 \text{ kg/m}^3$   |

#### Allowed supported construction

rigid supporting construction min.  $600 \text{ kg/m}^3$ ; min. 115 mm thickness

# POLFLAM EW 30 TGU

## Installation of POLFLAM glass in timber structures

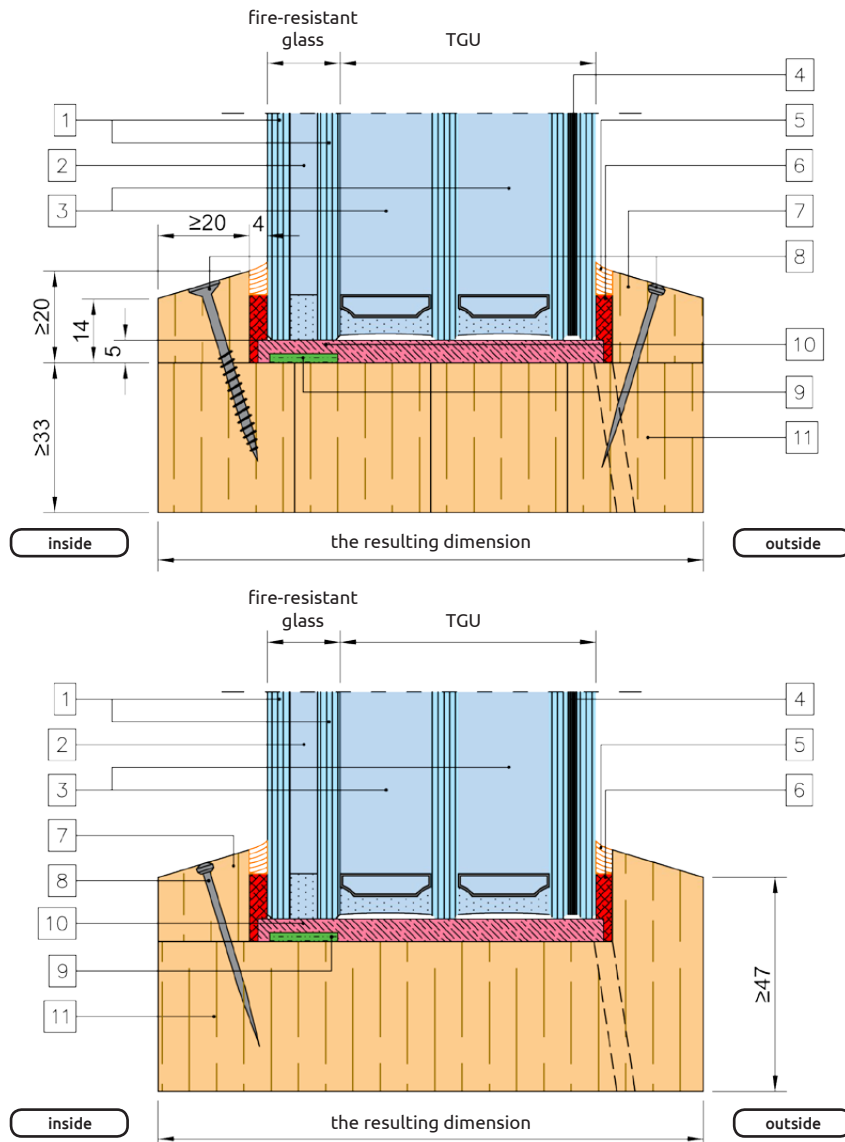

### POLFLAM EW 30 (16 mm) TGU

#### Partition wall

#### max. glass dimensions

1500 mm x 3000 mm ( $A_{\max} = 4,5 \text{ m}^2$ ) - portrait

2310 mm x 1500 mm ( $A_{\max} = 3,46 \text{ m}^2$ ) - landscape

reference document: Test report LBO-1525/21

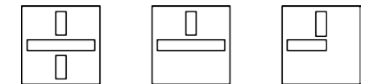

|    |   |
|----|---|
| 1  | thermally toughened glass $\geq 5 \text{ mm}$ thickness<br>thermally toughened patterned glass $\geq 6 \text{ mm}$ thickness<br>(individual panes can be tinted, coated, surface treated) |
| 2  | hydrogel interlayer $\geq 6 \text{ mm}$ thickness   |
| 3  | spacer $8 \div 20 \text{ mm}$ thickness   |
| 4  | glass $\geq 4 \text{ mm}$ thickness:<br>- float;<br>- thermally toughened glass (ESG);<br>- laminated glass (VSG);<br>(individual panes can be tinted, coated, surface treated)           |
| 5  | silicon Dowsil 791  |
| 6  | ceramic tape KERAFIX 2000 $15 \times 4 \text{ mm}$  |
| 7  | glazing bead $\geq 20 \text{ mm} \times 20/14 \text{ mm}$ , timber $\geq 560 \text{ kg/m}^3$  |
| 8  | nail min. $16\text{GA} \times 40 \text{ mm}$ or screw $\text{Ø}3,5 \times 40 \text{ mm}$<br>(20-40 mm from the corner and every 200 mm)   |
| 9  | intumescent tape KERAFIX FXL200 $20 \times 2 \text{ mm}$  |
| 10 | supporting block $5 \text{ mm}$   |
| 11 | laminated or solid timber $\geq 560 \text{ kg/m}^3$   |

#### Allowed supported construction

rigid supporting construction min.  $600 \text{ kg/m}^3$ ; min.  $115 \text{ mm}$  thickness

# POLFLAM EI 30

## Installation of POLFLAM glass in timber structures

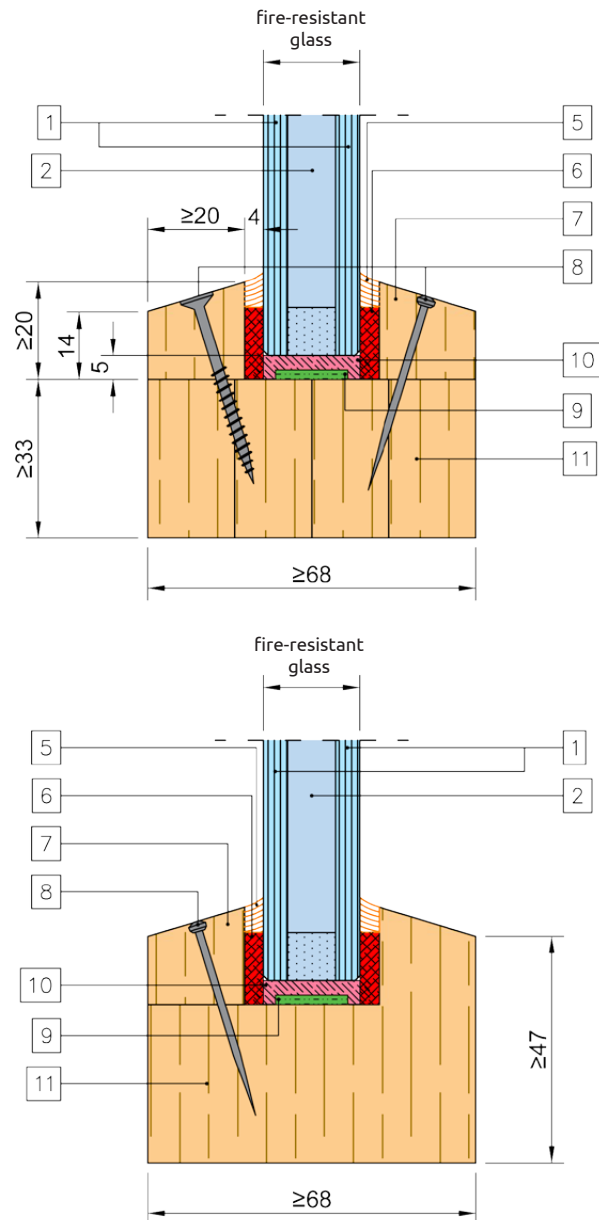

### POLFLAM EI 30 (20/22 mm)

#### Partition wall

#### max. glass dimensions

1800 mm x 4200 mm ( $A_{max} = 6,35 \text{ m}^2$ ) - portrait

3600 mm x 1800 mm ( $A_{max} = 5,45 \text{ m}^2$ ) - landscape

reference document: Test Report DMT-DO-61-174

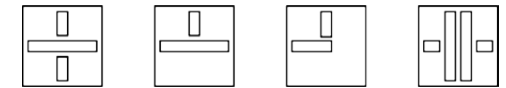

|           |   |
|-----------|---|
| <b>1*</b> | thermally toughened glass $\geq 5 \text{ mm}$ thickness<br>thermally toughened patterned glass $\geq 6 \text{ mm}$ thickness<br>(individual panes can be tinted, coated, surface treated) |
| <b>2</b>  | hydrogel interlayer $\geq 10 \text{ mm}$ thickness  |
| <b>5</b>  | silicon Dowsil 791  |
| <b>6</b>  | ceramic tape KERAFIX 2000 15 x 4 mm   |
| <b>7</b>  | glazing bead $\geq 20 \text{ mm} \times 20/14 \text{ mm}$ , timber $\geq 560 \text{ kg/m}^3$  |
| <b>8</b>  | nail min. 16GA x 40 mm or screw $\varnothing 3,5 \times 40 \text{ mm}$<br>(20-40 mm from the corner and every 200 mm)   |
| <b>9</b>  | intumescent tape KERAFIX FXL200 20 x 2 mm   |
| <b>10</b> | supporting block 5 mm   |
| <b>11</b> | laminated or solid timber $\geq 560 \text{ kg/m}^3$   |

#### Allowed supported construction

rigid supporting construction min.  $650 \text{ kg/m}^3$ ; min. 150 mm thickness

flexible supporting construction EI 30 min. 100 mm

\* above glass dimension over 1500 x 3000 mm or area over 4,5 m<sup>2</sup>  
glass pane pos.1 – min. 6 mm thickness

# POLFLAM EI 30 DGU

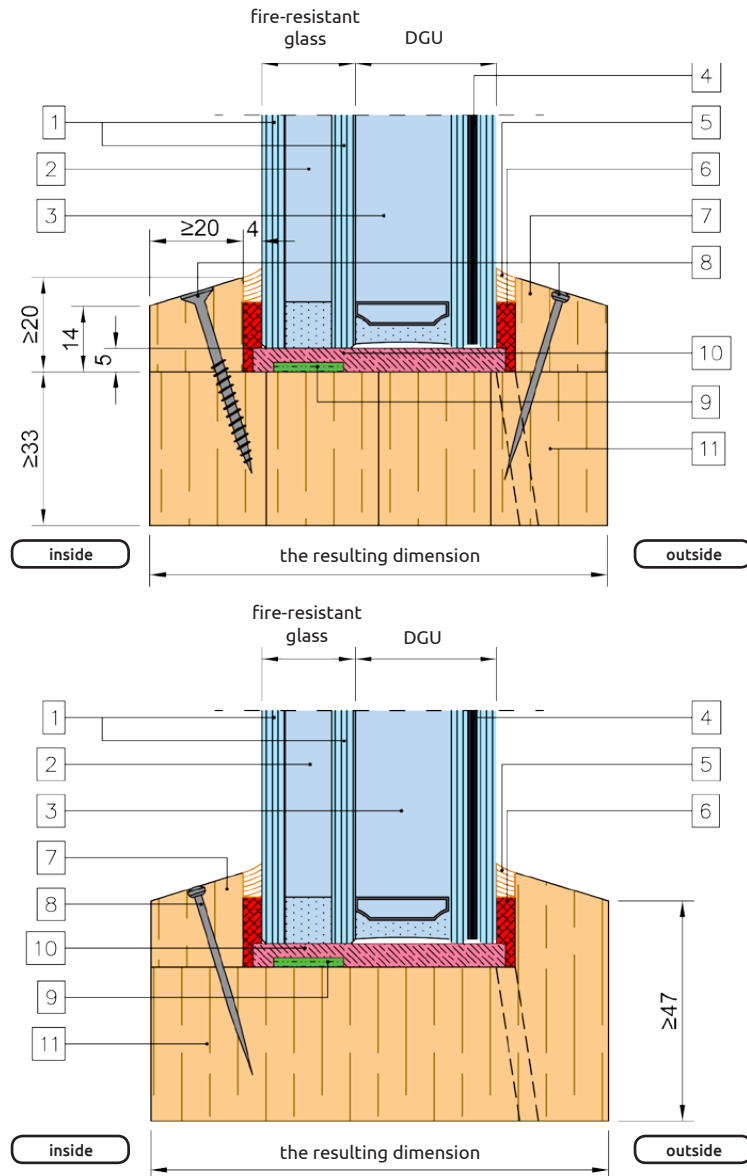

## Installation of POLFLAM glass in timber structures

### POLFLAM EI 30 (20/22 mm) DGU

#### Partition wall

|                              |  |
|------------------------------|--|
| <b>max. glass dimensions</b> | 1800 mm x 4200 mm ( $A_{max} = 6,35 \text{ m}^2$ ) - portrait  |
|                              | 3600 mm x 1800 mm ( $A_{max} = 5,45 \text{ m}^2$ ) - landscape |

reference document: Test Report DMT-DO-61-179

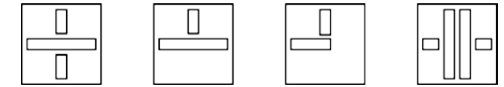

|           |   |
|-----------|---|
| <b>1*</b> | thermally toughened glass $\geq 5$ mm thickness<br>thermally toughened patterned glass $\geq 6$ mm thickness<br>(individual panes can be tinted, coated, surface treated) |
| <b>2</b>  | hydrogel interlayer $\geq 10$ mm thickness  |
| <b>3</b>  | spacer $8 \div 20$ mm thickness   |
| <b>4</b>  | glass $\geq 4$ mm thickness:<br>- float;<br>- thermally toughened glass (ESG);<br>- laminated glass (VSG);<br>(individual panes can be tinted, coated, surface treated)   |
| <b>5</b>  | silicon Dowsil 791  |
| <b>6</b>  | ceramic tape KERAFIX 2000 15 x 4 mm   |
| <b>7</b>  | glazing bead $\geq 20$ mm x 20/14 mm, timber $\geq 560 \text{ kg/m}^3$  |
| <b>8</b>  | nail min. 16GA x 40 mm or screw $\varnothing 3,5$ x 40 mm<br>(20-40 mm from the corner and every 200 mm)  |
| <b>9</b>  | intumescent tape KERAFIX FXL200 20 x 2 mm   |
| <b>10</b> | supporting block 5 mm   |
| <b>11</b> | laminated or solid timber $\geq 560 \text{ kg/m}^3$   |

#### Allowed supported construction

rigid supporting construction min.  $650 \text{ kg/m}^3$ ; min. 150 mm thickness  
flexible supporting construction EI 30 min. 100 mm

\* above glass dimension over 1500 x 3000 mm or area over  $4,5 \text{ m}^2$   
glass pane pos.1 – min. 6 mm thickness

# POLFLAM EI 30 TGU

## Installation of POLFLAM glass in timber structures

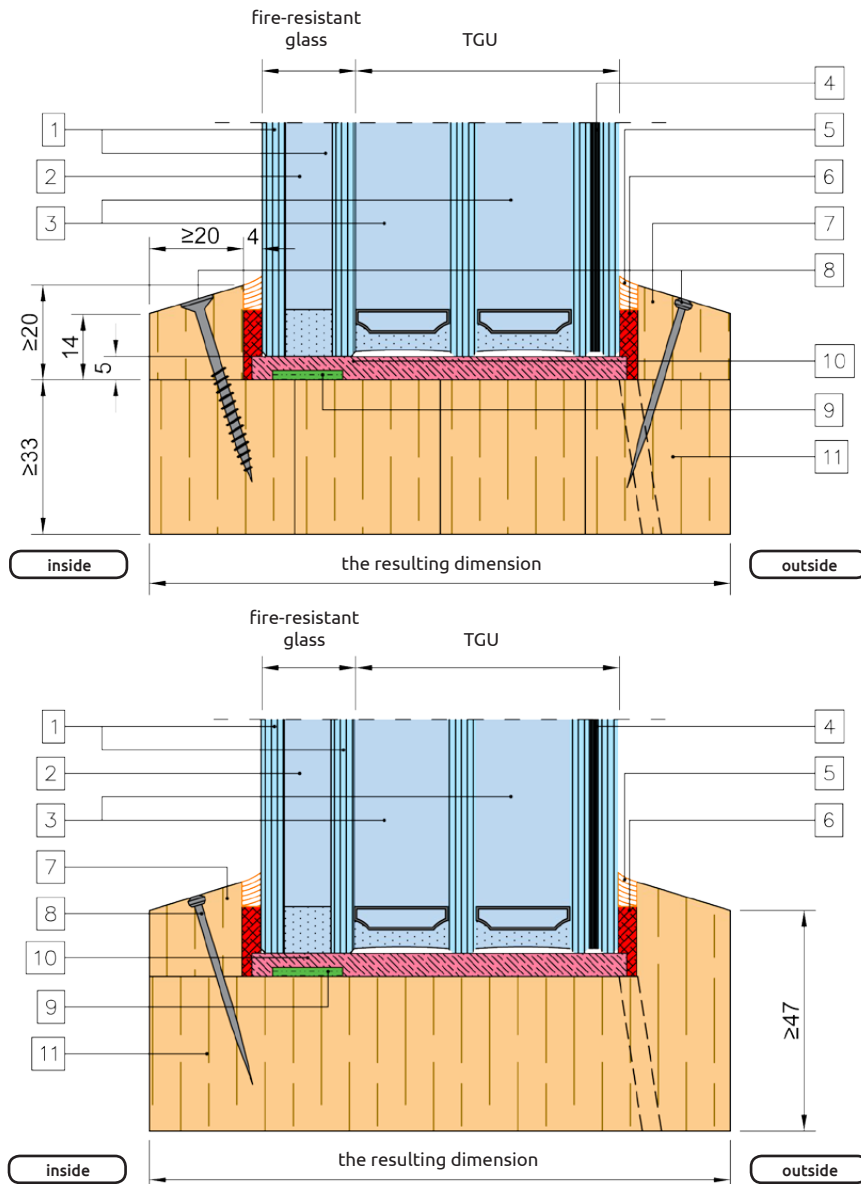

### POLFLAM EI 30 (20/22 mm) TGU

#### Partition wall

|                              |  |
|------------------------------|--|
| <b>max. glass dimensions</b> | 1800 mm x 4200 mm ( $A_{max} = 6,35 \text{ m}^2$ ) - portrait  |
|                              | 3600 mm x 1800 mm ( $A_{max} = 5,45 \text{ m}^2$ ) - landscape |

reference document: Test Report DMT-DO-61-179

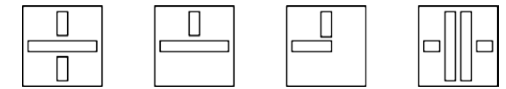

|           |   |
|-----------|---|
| <b>1*</b> | thermally toughened glass $\geq 5$ mm thickness<br>thermally toughened patterned glass $\geq 6$ mm thickness<br>(individual panes can be tinted, coated, surface treated) |
| <b>2</b>  | hydrogel interlayer $\geq 10$ mm thickness  |
| <b>3</b>  | spacer $8 \div 20$ mm thickness   |
| <b>4</b>  | glass $\geq 4$ mm thickness:<br>- float;<br>- thermally toughened glass (ESG);<br>- laminated glass (VSG)<br>(individual panes can be tinted, coated, surface treated)    |
| <b>5</b>  | silicon Dowsil 791  |
| <b>6</b>  | ceramic tape KERAFIX 2000 15 x 4 mm   |
| <b>7</b>  | glazing bead $\geq 20$ mm x 20/14 mm, timber $\geq 560 \text{ kg/m}^3$  |
| <b>8</b>  | nail min. 16GA x 40 mm or screw $\varnothing 3,5$ x 40 mm<br>(20-40 mm from the corner and every 200 mm)  |
| <b>9</b>  | intumescent tape KERAFIX FXL200 20 x 2 mm   |
| <b>10</b> | supporting block 5 mm   |
| <b>11</b> | laminated or solid timber $\geq 560 \text{ kg/m}^3$   |

#### Allowed supported construction

rigid supporting construction min.  $650 \text{ kg/m}^3$ ; min. 150 mm thickness  
flexible supporting construction EI 30 min. 100 mm

\* above glass dimension over 1500 x 3000 mm or area over  $4,5 \text{ m}^2$   
glass pane pos.1 – min. 6 mm thickness

# POLFLAM EI 30

## Installation of POLFLAM glass in timber structures

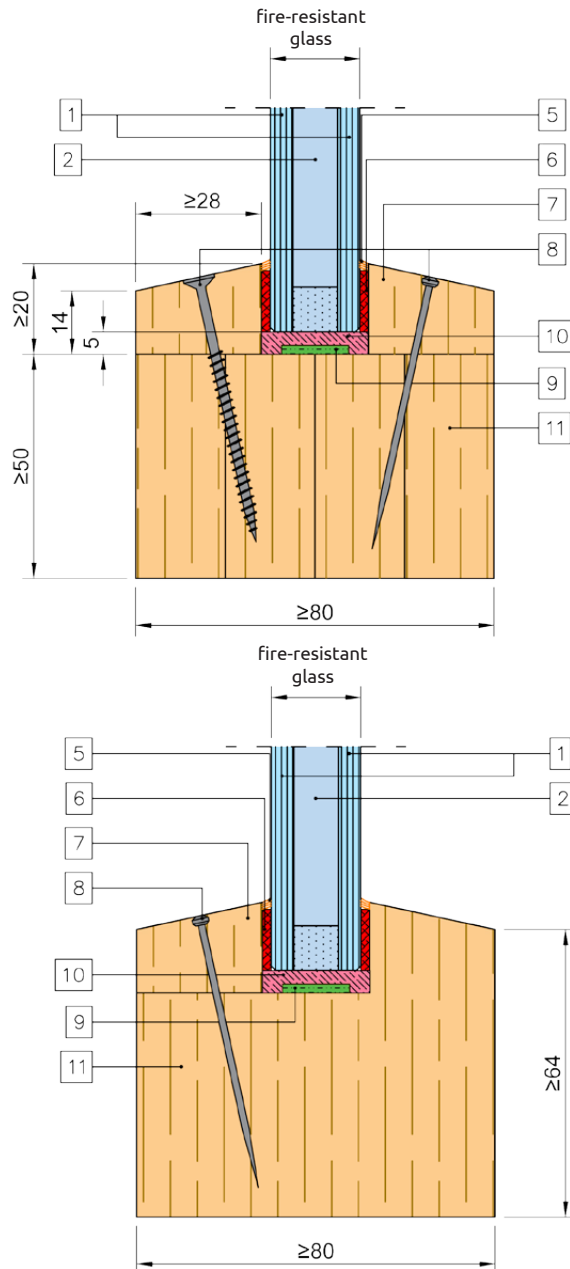

### POLFLAM EI 30 (20 mm)

#### Partition wall

|                              |  |
|------------------------------|--|
| <b>max. glass dimensions</b> | 1500 mm x 3000 mm ( $A_{\max} = 4,5 \text{ m}^2$ ) - portrait  |
|                              | 1500 mm x 3000 mm ( $A_{\max} = 4,5 \text{ m}^2$ ) - landscape |

reference document: LZP01-02135/19/Z00NZP

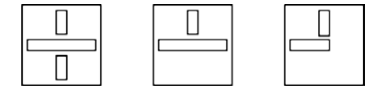

|           |   |
|-----------|---|
| <b>1</b>  | thermally toughened glass $\geq 5 \text{ mm}$ thickness<br>thermally toughened patterned glass $\geq 6 \text{ mm}$ thickness<br>(individual panes can be tinted, coated, surface treated) |
| <b>2</b>  | hydrogel interlayer $\geq 10 \text{ mm}$ thickness  |
| <b>5</b>  | silicon Dowsil 700 Fire Stop Sealant  |
| <b>6</b>  | expanding tape Hanno HANNO Werk   |
| <b>7</b>  | glazing bead $\geq 28 \text{ mm} \times 20/14 \text{ mm}$ timber $480 \text{ kg/m}^3$   |
| <b>8</b>  | nail $\varnothing 1,8 \times 60 \text{ mm}$ or screw $\varnothing 3,5 \times 60 \text{ mm}$<br>(50 mm from the corner and every 200 mm)   |
| <b>9</b>  | tape PROMAT Promaseal-LW 2 x 30 mm  |
| <b>10</b> | supporting block 5 mm   |
| <b>11</b> | laminated or solid timber $480 \text{ kg/m}^3$  |

#### Allowed supported construction

aerated concrete



# POLFLAM EI 30

## Installation of POLFLAM glass in timber structures

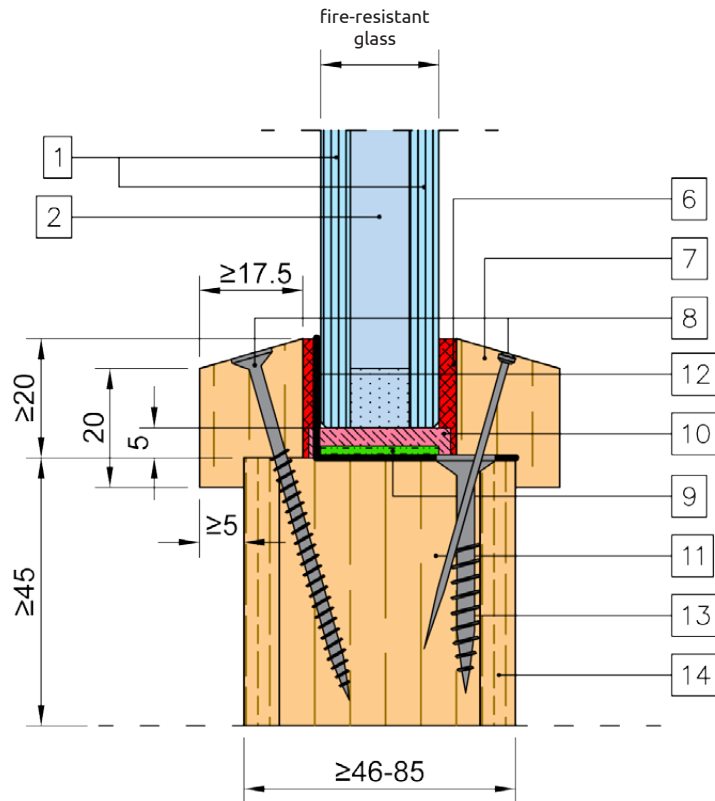

| POLFLAM EI 30 (20 mm)                 |                              |
|---------------------------------------|------------------------------|
| Door                                  |                              |
| max. glass dimensions                 | 658 mm x 1638 mm - portrait  |
|                                       | 658 mm x 1638 mm - landscape |
| reference document: ITB-KOT-2018/0407 |                              |



|    |   |
|----|---|
| 1  | thermally toughened glass $\geq 5$ mm thickness<br>thermally toughened patterned glass $\geq 6$ mm thickness<br>(individual panes can be tinted, coated, surface treated) |
| 2  | hydrogel interlayer $\geq 10$ mm thickness  |
| 6  | ceramic tape KERAFIX 2000 8 x 4 mm,<br>PROMAGLAF-HTI 1100 8 x 4 mm, FIBERFRAX 20 x 4 mm   |
| 7  | glazing bead $\geq 20$ mm x $\geq 17,5$ mm timber 350 kg/m <sup>3</sup>   |
| 8  | screw $\varnothing 3$ x 70 mm or nail $\varnothing 1,2$ x 50<br>(50 mm from the corner and every 200 mm)  |
| 9  | intumescent tape: PROMAT Promaseal-HT 1,6 mm,<br>Halspan Glazing Seal 10 x 3 mm<br>or 25 x 3mm, Halspan K 3mm, Therm-A-Line 2 mm  |
| 10 | supporting block 5 mm   |
| 11 | multi-layer chipboard 530 kg/m <sup>3</sup>   |
| 12 | glass fixing bracket<br>(according to reference document)   |
| 13 | screw $\varnothing 5$ x 40 mm   |
| 14 | HDF board 1÷6 mm 800 kg/m <sup>3</sup>  |

# POLFLAM EI 45

## Installation of POLFLAM glass in timber structures

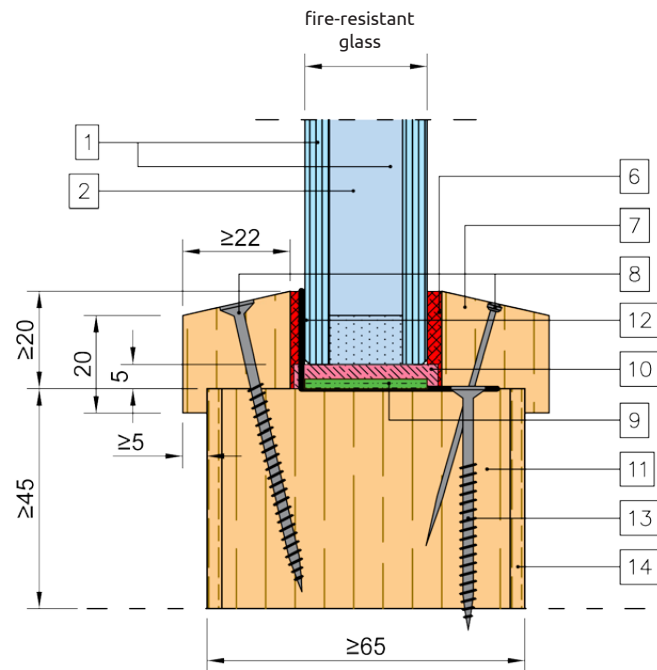

| POLFLAM EI 45 (25 mm)             |                              |
|-----------------------------------|------------------------------|
| Door                              |                              |
| max. glass dimensions             | 907 mm x 1980 mm - portrait  |
|                                   | 907 mm x 1980 mm - landscape |
| reference document: 506/14/Z000NP |                              |



|    |   |
|----|---|
| 1  | thermally toughened glass $\geq 5$ mm thickness<br>thermally toughened patterned glass $\geq 6$ mm thickness<br>(individual panes can be tinted, coated, surface treated) |
| 2  | hydrogel interlayer $\geq 15$ mm thickness  |
| 6  | ceramic tape KERAFIX 2000 8 x 4 mm  |
| 7  | glazing bead $\geq 20$ mm x $\geq 17,5$ mm timber 350 kg/m <sup>3</sup>   |
| 8  | screw $\varnothing 3$ x 70 mm or nail $\varnothing 1,2$ x 50<br>(50 mm from the corner and every 200 mm)  |
| 9  | intumescent tape PROMAT Promaseal-HT 1,6 x 25 mm  |
| 10 | supporting block 5 mm   |
| 11 | multi-layer chipboard 530 kg/m <sup>3</sup>   |
| 12 | glass fixing bracket<br>(according to reference document)   |
| 13 | screw $\varnothing 3,5$ x 50 mm   |
| 14 | HDF board 3 mm 800 kg/m <sup>3</sup>  |

# POLFLAM EW 60

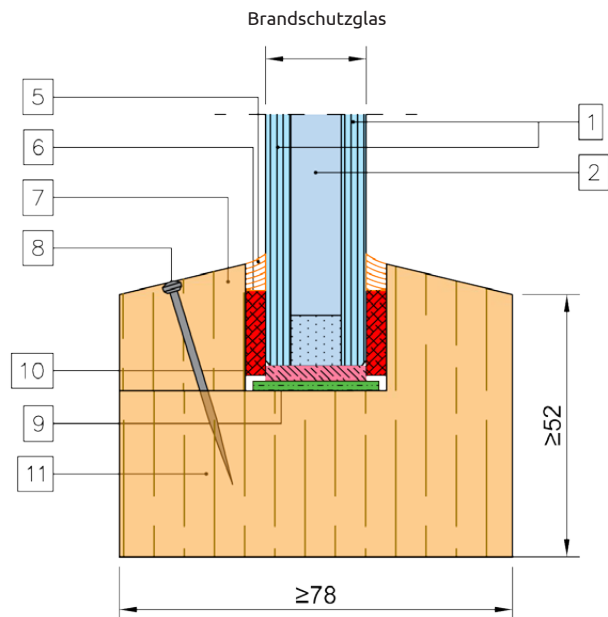
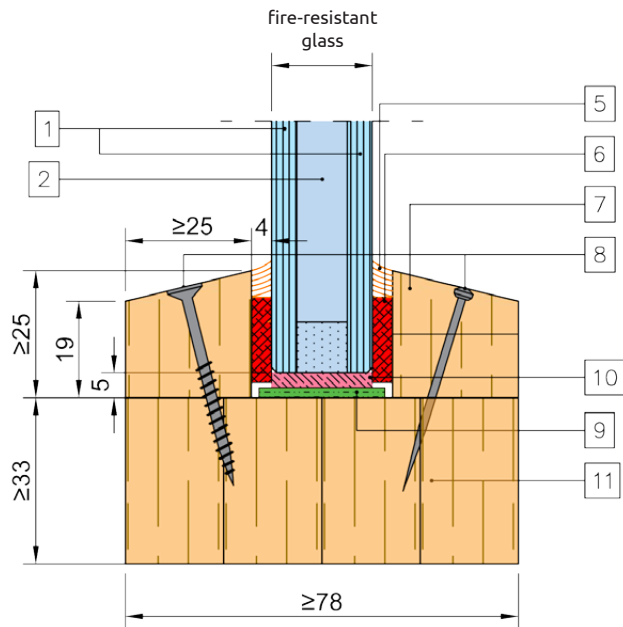

## Installation of POLFLAM glass in timber structures

### POLFLAM EW 60 (20 mm)

#### Partition wall

|                              |   |
|------------------------------|---|
| <b>max. glass dimensions</b> | 1500 mm x 3000 mm ( $A_{max} = 4,5 \text{ m}^2$ ) - portrait  |
|                              | 2310 mm x 1500 mm ( $A_{max} = 3,47 \text{ m}^2$ ) - portrait |

reference document: Test Report LBO-191-N/21

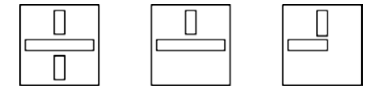

|           |   |
|-----------|---|
| <b>1</b>  | thermally toughened glass $\geq 5$ mm thickness<br>thermally toughened patterned glass $\geq 6$ mm thickness<br>(individual panes can be tinted, coated, surface treated) |
| <b>2</b>  | hydrogel interlayer $\geq 10$ mm thickness  |
| <b>5</b>  | silicon Dowsil 791  |
| <b>6</b>  | ceramic tape KERAFIX 2000 17 x 4mm  |
| <b>7</b>  | glazing bead $\geq 25\text{mm} \times 25/19$ mm timber $\geq 650\text{kg/m}^3$  |
| <b>8</b>  | nail min. 16GA x 40 mm or screw $\varnothing 3,5 \times 40\text{mm}$<br>(20-40 mm from the corner and every 200 mm)   |
| <b>9</b>  | intumescent tape KERAFIX FXL200 25 x 2mm  |
| <b>10</b> | supporting block 5 mm   |
| <b>11</b> | laminated or solid timber profile $\geq 650 \text{ kg/m}^3$   |

#### Allowed supported construction

rigid supporting construction min.  $600 \text{ kg/m}^3$ ; min. 150 mm thickness

# POLFLAM EI 60

## Installation of POLFLAM glass in timber structures

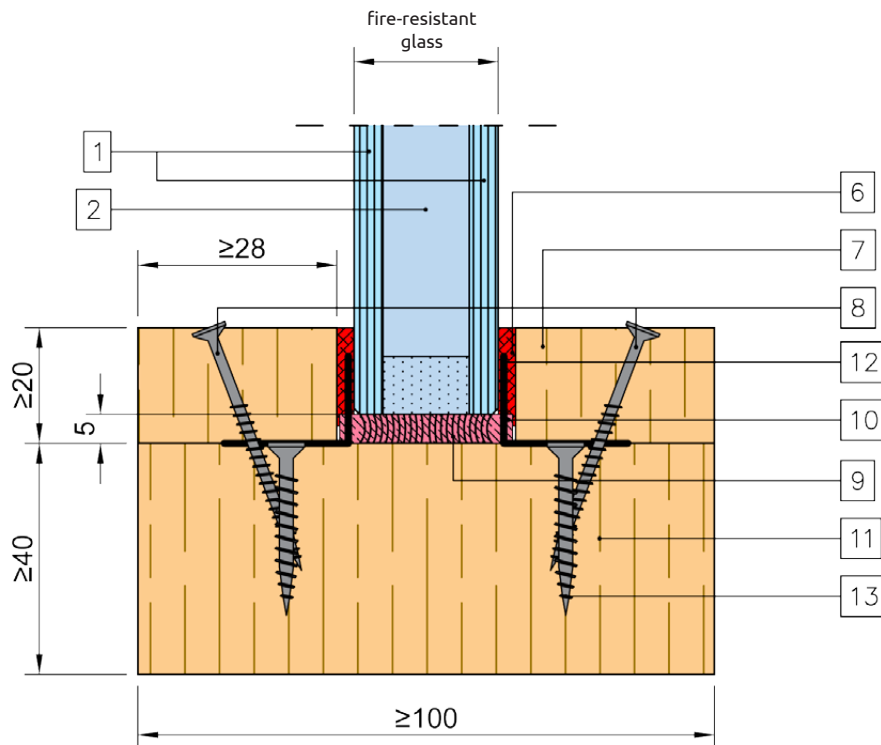

| POLFLAM EI 60 (25 mm)               |                               |
|-------------------------------------|-------------------------------|
| Partition wall                      |                               |
| max. glass dimensions               | 1090 mm x 2290 mm - portrait  |
|                                     | 1090 mm x 2290 mm - landscape |
| reference document: AT-15-5216/2015 |                               |

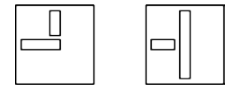

|    |   |
|----|---|
| 1  | thermally toughened glass $\geq 5$ mm thickness<br>thermally toughened patterned glass $\geq 6$ mm thickness<br>(individual panes can be tinted, coated, surface treated) |
| 2  | hydrogel interlayer $\geq 15$ mm thickness  |
| 6  | ceramic tape Gluske 6 x 17 mm   |
| 7  | glazing bead $\geq 20$ mm x $\geq 28$ mm timber 650 kg/m <sup>3</sup>   |
| 8  | screw $\varnothing 3$ x 45 mm   |
| 9  | fireproof seal: PROMAT Promaseal mastic, Den Braven Pyrocryl, DenBraven Pyropol, Pyroplex AC4   |
| 10 | supporting block 5 mm   |
| 11 | multi-layer plywood profile 650 kg/m <sup>3</sup>   |
| 12 | glass fixing bracket<br>(50 mm from the corner and every 150 mm)  |
| 13 | screw $\varnothing 4$ x 30 mm   |

### Allowed supported construction

wall of ceramic, concrete or silicate bricks, wall of concrete and reinforced concrete, wall of cellular bricks or perforated bricks, plasterboard wall

# POLFLAM EI 60 DGU

## Installation of POLFLAM glass in timber structures

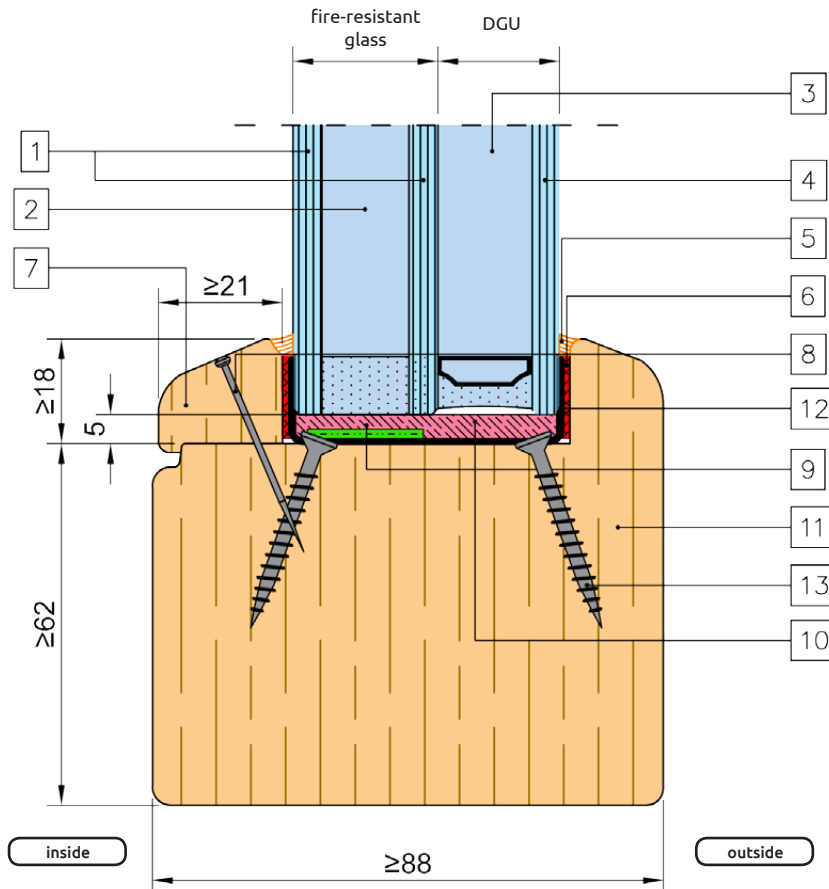

### POLFLAM EI 60 (25 mm) DGU

#### Partition wall

#### max. glass dimensions

1526 mm x 1828 mm - portrait

1526 mm x 1828 mm - landscape

reference document: LBO-1228.1/18

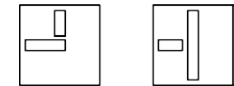

|    |   |
|----|---|
| 1  | thermally toughened glass $\geq 5$ mm thickness<br>thermally toughened patterned glass $\geq 6$ mm thickness<br>(individual panes can be tinted, coated, surface treated) |
| 2  | hydrogel interlayer $\geq 15$ mm thickness  |
| 3  | spacer $8 \div 20$ mm thickness   |
| 4  | glass $\geq 4$ mm thickness:<br>- float;<br>- thermally toughened glass (ESG);<br>- laminated glass (VSG)<br>(individual panes can be tinted, coated, surface treated)    |
| 5  | PROMAT Mastic   |
| 6  | intumescent tape PROMAT Promaseal-LW 1 x 10 mm  |
| 7  | glazing bead $\geq 21$ mm x 18 mm timber $700 \text{ kg/m}^3$   |
| 8  | nail $\text{Ø}1,1 \times 1,1 \times 35$ mm (50 mm from the corner and every 200 mm)   |
| 9  | intumescent tape PROMAT Promaseal-LW 2 x 28 mm  |
| 10 | supporting block 3 mm   |
| 11 | laminated or solid timber $700 \text{ kg/m}^3$  |
| 12 | glass fixing bracket (150 mm from the corner and every 350 mm)  |
| 13 | screw $\text{Ø}4 \times 35$ mm  |

**Allowed supported construction:** aerated concrete

# POLFLAM EI 60

## Installation of POLFLAM glass in timber structures

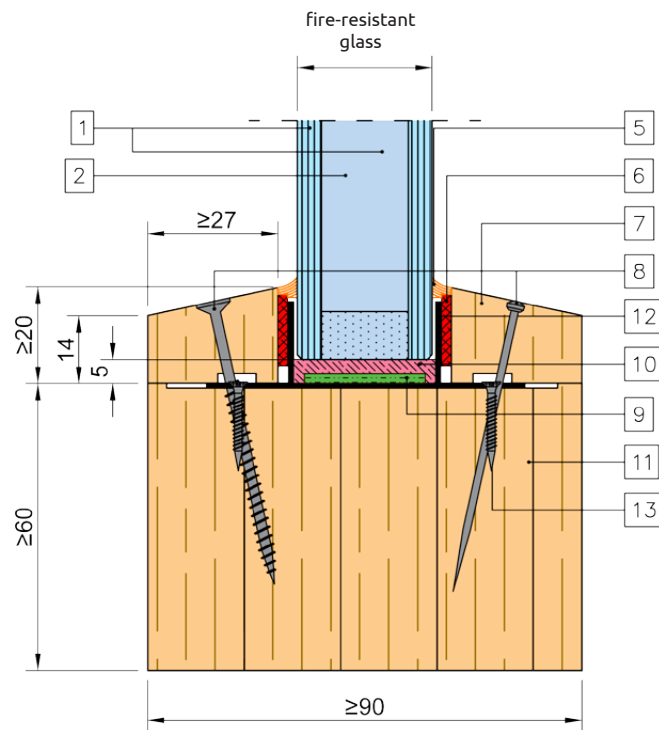

### POLFLAM EI 60 (28 mm)

#### Partition wall

|   |  |
|---|--|
| <b>max. glass dimensions</b>              | 1500 mm x 3000 mm ( $A_{\max} = 4,5 \text{ m}^2$ ) - portrait  |
|   | 1500 mm x 3000 mm ( $A_{\max} = 4,5 \text{ m}^2$ ) - landscape |
| reference document: LZP03-02135/19/Z00NZP |  |

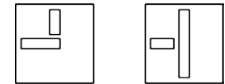

|           |   |
|-----------|---|
| <b>1</b>  | thermally toughened glass $\geq 5$ mm thickness<br>thermally toughened patterned glass $\geq 6$ mm thickness<br>(individual panes can be tinted, coated, surface treated) |
| <b>2</b>  | hydrogel interlayer $\geq 18$ mm thickness  |
| <b>5</b>  | silicon Dowsil 700 Fire Stop Sealant  |
| <b>6</b>  | expanding tape Hanno HANNO Werk   |
| <b>7</b>  | glazing bead $\geq 27$ mm x 20/14 mm timber 580 kg/m <sup>3</sup>   |
| <b>8</b>  | nail $\varnothing 1,8$ x 60 mm or screw $\varnothing 3,5$ x 60 mm<br>(50 mm from the corner and every 200 mm)   |
| <b>9</b>  | tape PROMAT Promaseal-LW 2 x 30 mm  |
| <b>10</b> | supporting block 5 mm   |
| <b>11</b> | laminated or solid timber 580 kg/m <sup>3</sup>   |
| <b>12</b> | stainless steel glazing bracket<br>(100 mm from the corner and every 300 mm)  |
| <b>13</b> | screw $\varnothing 2$ x 20 mm   |

#### Allowed supported construction

aerated concrete



# POLFLAM EI 60

## Installation of POLFLAM glass in timber structures

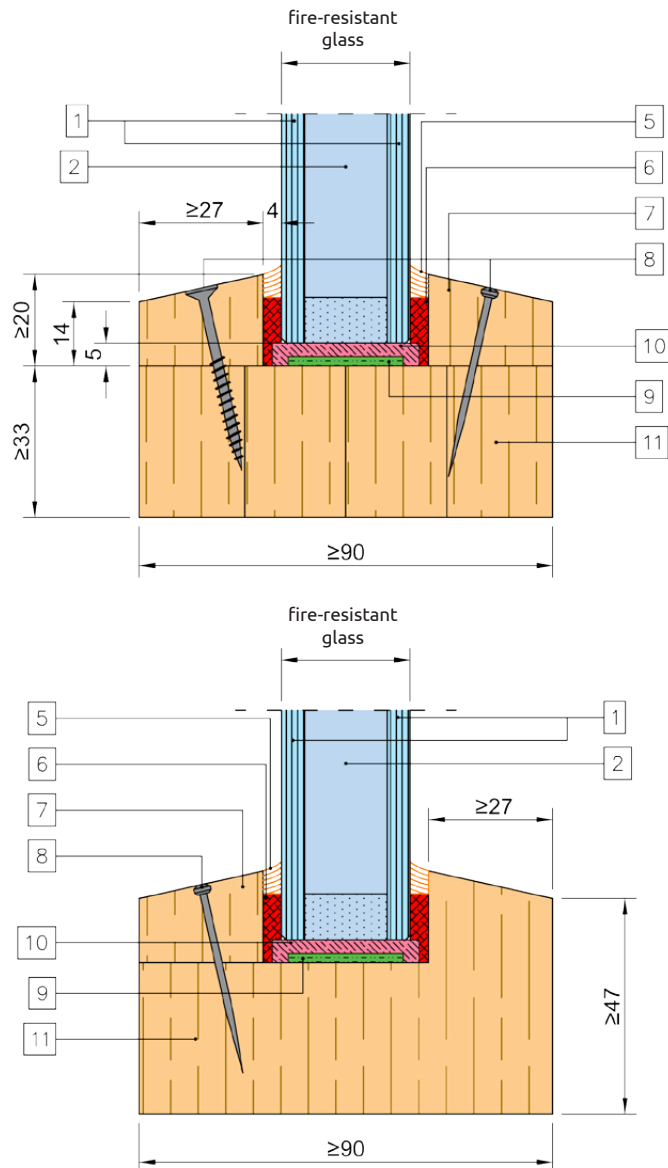

### POLFLAM EI 60 (28/30 mm)

#### Partition wall

#### max. glass dimensions

1800 mm x 4200 mm ( $A_{max} = 6,35 \text{ m}^2$ ) - portrait

3600 mm x 1800 mm ( $A_{max} = 5,45 \text{ m}^2$ ) - landscape

reference document: Test Report DMT-DO-61-185

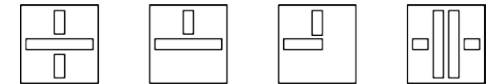

|           |   |
|-----------|---|
| <b>1*</b> | thermally toughened glass $\geq 5 \text{ mm}$ thickness<br>thermally toughened patterned glass $\geq 6 \text{ mm}$ thickness<br>(individual panes can be tinted, coated, surface treated) |
| <b>2</b>  | hydrogel interlayer $\geq 18 \text{ mm}$ thickness  |
| <b>5</b>  | silicon Dowsil 791  |
| <b>6</b>  | ceramic tape KERAFIX 2000 15 x 4 mm   |
| <b>7</b>  | glazing bead $\geq 27 \text{ mm} \times 20/14 \text{ mm}$ , timber 650 kg/m <sup>3</sup>  |
| <b>8</b>  | nail min. 16GA x 40 mm or screw $\varnothing 3,5 \times 40 \text{ mm}$<br>(20-40 mm from the corner and every 200 mm)   |
| <b>9</b>  | intumescent tape KERAFIX FXL200 30 x 2 mm   |
| <b>10</b> | supporting block 5 mm   |
| <b>11</b> | laminated or solid timber $\geq 650 \text{ kg/m}^3$   |

#### Allowed supported construction

rigid supporting construction min. 550 kg/m<sup>3</sup>; min. 150 mm thickness  
flexible supporting construction EI 60 min. 125 mm

\* above glass dimension over 1500 x 3000 mm or area over 4,5 m<sup>2</sup>  
glass pane pos.1 – min. 6 mm thickness

# POLFLAM EI 60 DGU

## Installation of POLFLAM glass in timber structures

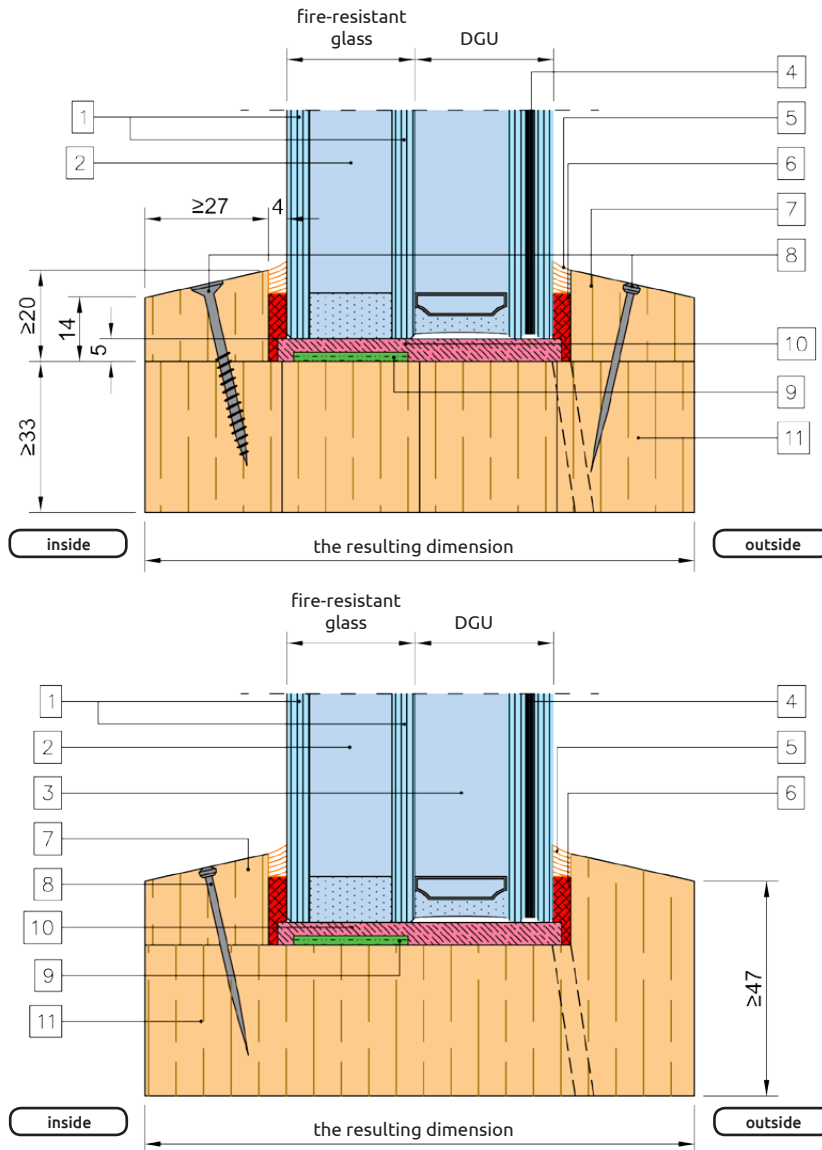

### POLFLAM EI 60 (28/30 mm) DGU

#### Partition wall

#### max. glass dimensions

1800 mm x 4200 mm ( $A_{max} = 6,35 \text{ m}^2$ ) - portrait

3600 mm x 1800 mm ( $A_{max} = 5,45 \text{ m}^2$ ) - landscape

reference document: Raport DMT-DO-61-186

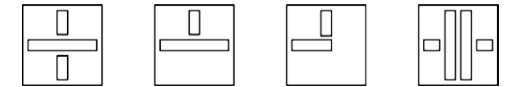

|    |   |
|----|---|
| 1* | thermally toughened glass $\geq 5 \text{ mm}$ thickness<br>thermally toughened patterned glass $\geq 6 \text{ mm}$ thickness<br>(individual panes can be tinted, coated, surface treated) |
| 2  | hydrogel interlayer $\geq 18 \text{ mm}$ thickness  |
| 3  | spacer $8 \div 20 \text{ mm}$ thickness   |
| 4  | glass $\geq 4 \text{ mm}$ thickness:<br>- float;<br>- thermally toughened glass (ESG);<br>- laminated glass (VSG);<br>(individual panes can be tinted, coated, surface treated)           |
| 5  | silicon Dowsil 791  |
| 6  | ceramic tape KERAFIX 2000 $15 \times 4 \text{ mm}$  |
| 7  | glazing bead $\geq 27 \text{ mm} \times 20/14 \text{ mm}$ , timber $\geq 650 \text{ kg/m}^3$  |
| 8  | nail min. $16\text{GA} \times 40 \text{ mm}$ or screw $\text{Ø}3,5 \times 40 \text{ mm}$<br>( $20\text{-}40 \text{ mm}$ from the corner and every $200 \text{ mm}$ )                      |
| 9  | intumescent tape KERAFIX FXL200 $30 \times 2 \text{ mm}$  |
| 10 | supporting block $5 \text{ mm}$   |
| 11 | laminated or solid timber $\geq 650 \text{ kg/m}^3$   |

#### Allowed supported construction

rigid supporting construction min.  $550 \text{ kg/m}^3$ ; min.  $150 \text{ mm}$  thickness  
flexible supporting construction EI 60 min.  $125 \text{ mm}$

\* above glass dimension over  $1500 \times 3000 \text{ mm}$  or area over  $4,5 \text{ m}^2$   
glass pane pos.1 – min.  $6 \text{ mm}$  thickness

# POLFLAM EI 60 TGU

## Installation of POLFLAM glass in timber structures

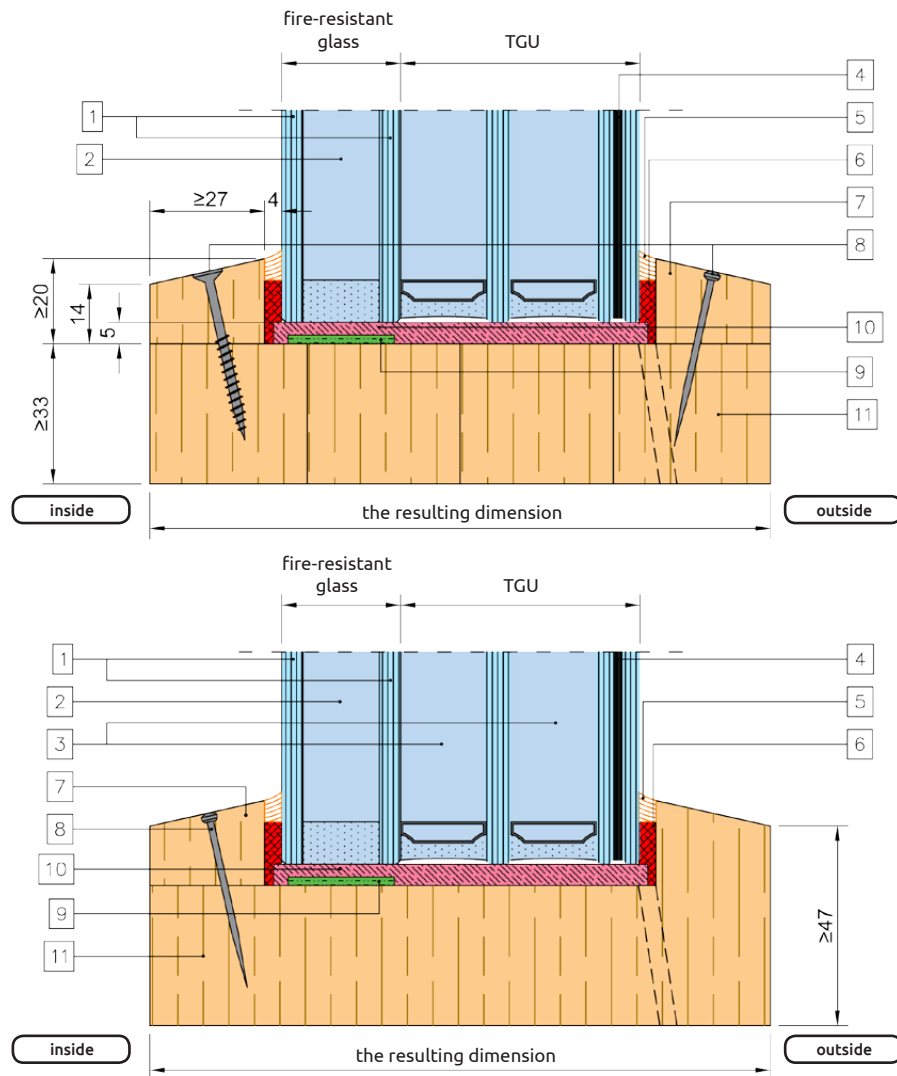

### POLFLAM EI 60 (28/30 mm) TGU

#### Partition wall

#### max. glass dimensions

1800 mm x 4200 mm ( $A_{max} = 6,35 \text{ m}^2$ ) - portrait

3600 mm x 1800 mm ( $A_{max} = 5,45 \text{ m}^2$ ) - landscape

reference document: Test Report DMT-DO-61-186

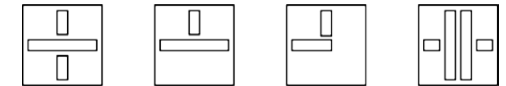

|    |   |
|----|---|
| 1* | thermally toughened glass $\geq 5 \text{ mm}$ thickness<br>thermally toughened patterned glass $\geq 6 \text{ mm}$ thickness<br>(individual panes can be tinted, coated, surface treated) |
| 2  | hydrogel interlayer $\geq 18 \text{ mm}$ thickness  |
| 3  | spacer $8 \div 20 \text{ mm}$ thickness   |
| 4  | glass $\geq 4 \text{ mm}$ thickness:<br>- float;<br>- thermally toughened glass (ESG);<br>- laminated glass (VSG);<br>(individual panes can be tinted, coated, surface treated)           |
| 5  | silicon Dowsil 791  |
| 6  | ceramic tape KERAFIX 2000 $15 \times 4 \text{ mm}$  |
| 7  | glazing bead $\geq 27 \text{ mm} \times 20/14 \text{ mm}$ , timber $\geq 650 \text{ kg/m}^3$  |
| 8  | nail min. 16GA x 40 mm or screw $\varnothing 3,5 \times 40 \text{ mm}$<br>(20-40 mm from the corner and every 200 mm)   |
| 9  | intumescent tape KERAFIX FXL200 $30 \times 2 \text{ mm}$  |
| 10 | supporting block 5 mm   |
| 11 | laminated or solid timber $\geq 650 \text{ kg/m}^3$   |

#### Allowed supported construction

rigid supporting construction min.  $550 \text{ kg/m}^3$ ; min. 150 mm thickness;  
flexible supporting construction EI 60 min. 125 mm

\* above glass dimension over  $1500 \times 3000 \text{ mm}$  or area over  $4,5 \text{ m}^2$   
glass pane pos.1 – min. 6 mm thickness

# POLFLAM EI 90

## Installation of POLFLAM glass in timber structures

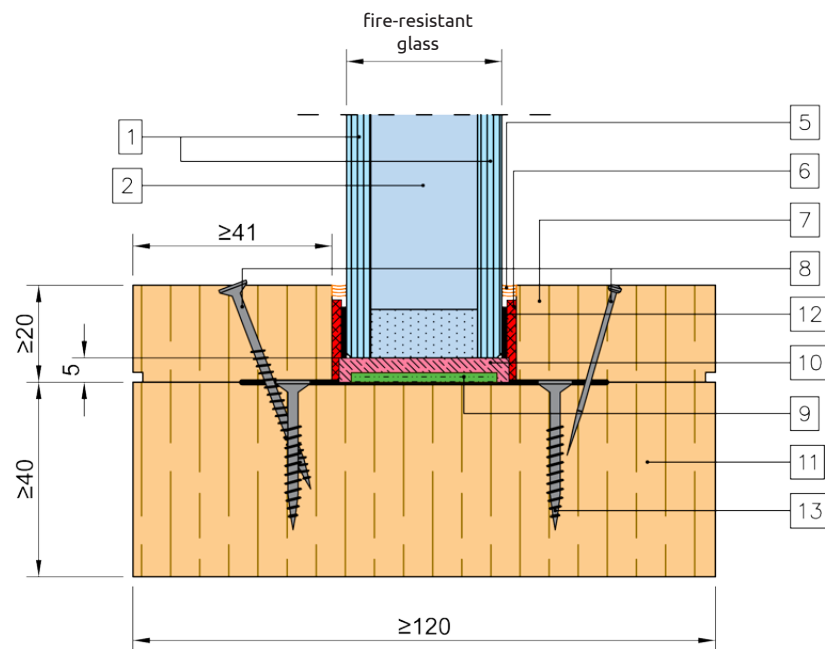

| POLFLAM EI 90 (32 mm)               |                             |
|-------------------------------------|-----------------------------|
| Partition wall                      |                             |
| max. glass dimensions               | 270 mm x 1625 mm - portrait |
| reference document: EFR-17-V-002021 |                             |

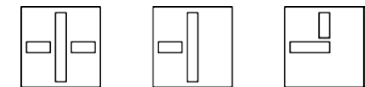

|    |   |
|----|---|
| 1  | thermally toughened glass $\geq 5$ mm thickness<br>thermally toughened patterned glass $\geq 6$ mm thickness<br>(individual panes can be tinted, coated, surface treated) |
| 2  | hydrogel interlayer $\geq 22$ mm thickness  |
| 5  | silicon PROMAT Systemglas   |
| 6  | ceramic tape KERAFIX 2000 2 x 15 mm   |
| 7  | glazing bead $\geq 20$ mm x $\geq 41$ mm timber 520 kg/m <sup>3</sup>   |
| 8  | screw $\varnothing 3$ x 45 mm or nail $\varnothing 1$ x 35<br>(50 mm from the corner and every 200 mm)  |
| 9  | intumescent tape or Kerafix FXL 200 2 x 30 mm   |
| 10 | supporting block PROMAT Flami 12 3 x 29 x 80 mm   |
| 11 | laminated or solid timber 520 kg/m <sup>3</sup>   |
| 12 | glass fixing bracket<br>(50 mm from the corner and every 200 mm)  |
| 13 | screw $\varnothing 3,5$ x 30 mm   |

| Allowed supported construction |  |
|--------------------------------|--|
| concrete                       |  |

# POLFLAM EI 90

## Installation of POLFLAM glass in timber structures

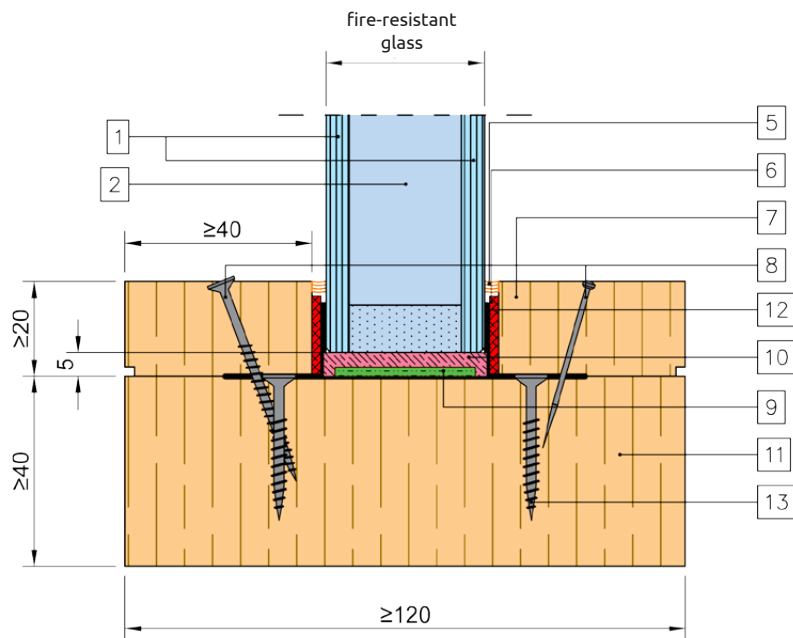

| POLFLAM EI 90 (34 mm)               |                              |
|-------------------------------------|------------------------------|
| Partition wall                      |                              |
| max. glass dimensions               | 2150 mm x 3300 mm - portrait |
| reference document: EFR-17-V-002021 |                              |

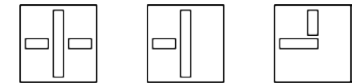

|    |   |
|----|---|
| 1  | thermally toughened glass $\geq 6$ mm thickness<br>thermally toughened patterned glass $\geq 6$ mm thickness<br>(individual panes can be tinted, coated, surface treated) |
| 2  | hydrogel interlayer $\geq 22$ mm thickness  |
| 5  | silicon PROMAT Systemglas   |
| 6  | ceramic tape KERAFIX 2000 2 x 15 mm   |
| 7  | glazing bead $\geq 20$ mm x $\geq 40$ mm timber 520 kg/m <sup>3</sup>   |
| 8  | screw $\varnothing 3$ x 45 mm or nail $\varnothing 1$ x 35<br>(50 mm from the corner and every 200 mm)  |
| 9  | intumescent tape or Kerafix FXL 200 2 x 30 mm   |
| 10 | supporting block PROMAT Flami 12 3 x 29 x 80 mm   |
| 11 | laminated or solid timber 520 kg/m <sup>3</sup>   |
| 12 | glass fixing bracket<br>(50 mm from the corner and every 200 mm)  |
| 13 | screw $\varnothing 3,5$ x 30 mm   |

| Allowed supported construction |  |
|--------------------------------|--|
| concrete                       |  |

# POLFLAM EI 90

## Installation of POLFLAM glass in timber structures

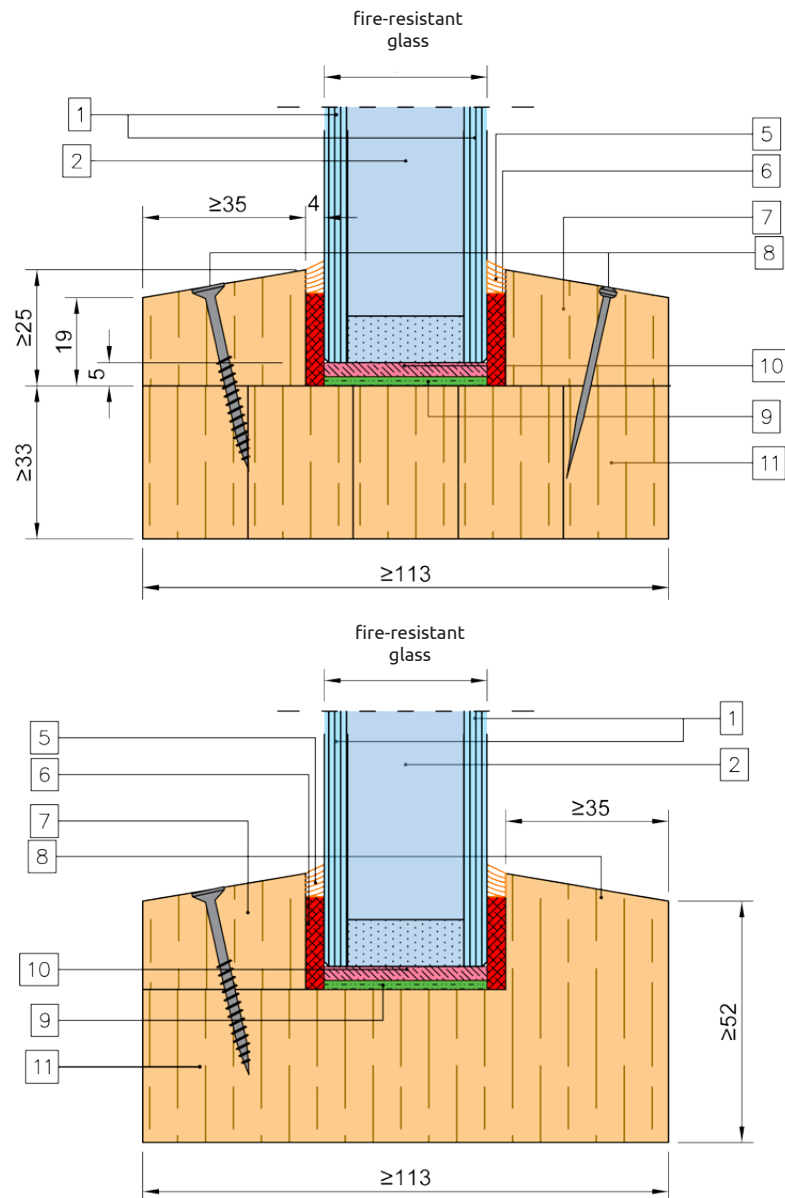

### POLFLAM EI 90 (35/37 mm) DGU

#### Partition wall

#### max. glass dimensions

2400 mm x 4200 mm ( $A_{max} = 8,47 \text{ m}^2$ ) - portrait

3600 mm x 1800 mm ( $A_{max} = 5,45 \text{ m}^2$ ) - landscape

reference document: DMT-DO-61-214, DMT-DO-61-215

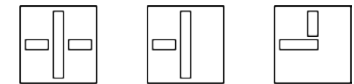

|    |   |
|----|---|
| 1* | thermally toughened glass $\geq 5 \text{ mm}$ thickness<br>thermally toughened patterned glass $\geq 6 \text{ mm}$ thickness<br>(individual panes can be tinted, coated, surface treated) |
| 2  | hydrogel interlayer $\geq 25 \text{ mm}$ thickness  |
| 3  | spacer $8 \div 20 \text{ mm}$ thickness   |
| 5  | silicon Dowsil 791  |
| 6  | ceramic tape KERAFIX 2000 $20 \times 4 \text{ mm}$  |
| 7  | glazing bead $\geq 35 \text{ mm} \times 25/19 \text{ mm}$ timber $\geq 650 \text{ kg/m}^3$  |
| 8  | nail min. 16GA x 50 mm or screw $\varnothing 3,5 \times 50 \text{ mm}$<br>(20-40 mm from the corner and every 150 mm)   |
| 9  | intumescent tape KERAFIX FXL200 $35 \times 2 \text{ mm}$  |
| 10 | supporting block 5mm  |
| 11 | laminated or solid timber $\geq 650 \text{ kg/m}^3$   |

#### Allowed supported construction

rigid supporting construction min.  $650 \text{ kg/m}^3$ ; min. 180 mm thickness  
flexible supporting construction EI 90 min. 125 mm

\* above glass dimension over  $1500 \times 3000 \text{ mm}$  or area over  $4,5 \text{ m}^2$   
glass pane pos.1 – min. 6 mm thickness



# POLFLAM EI 90 DGU

## Installation of POLFLAM glass in timber structures

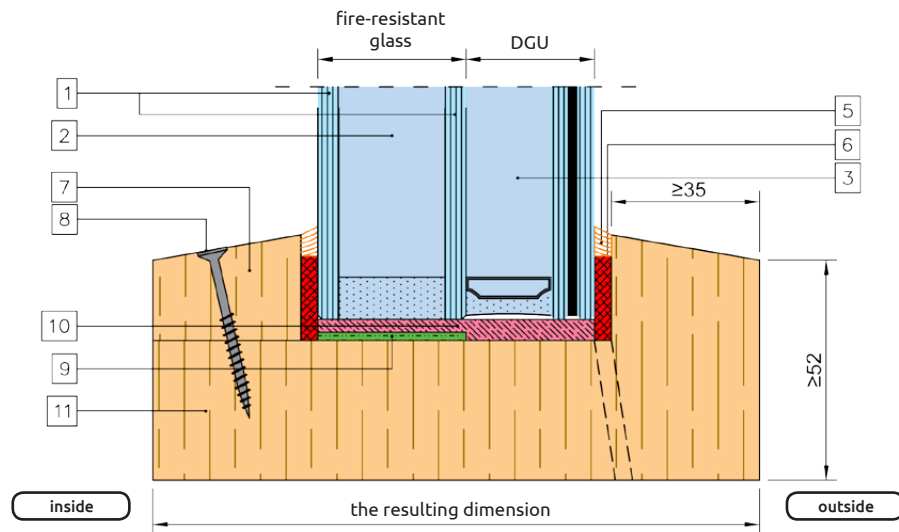
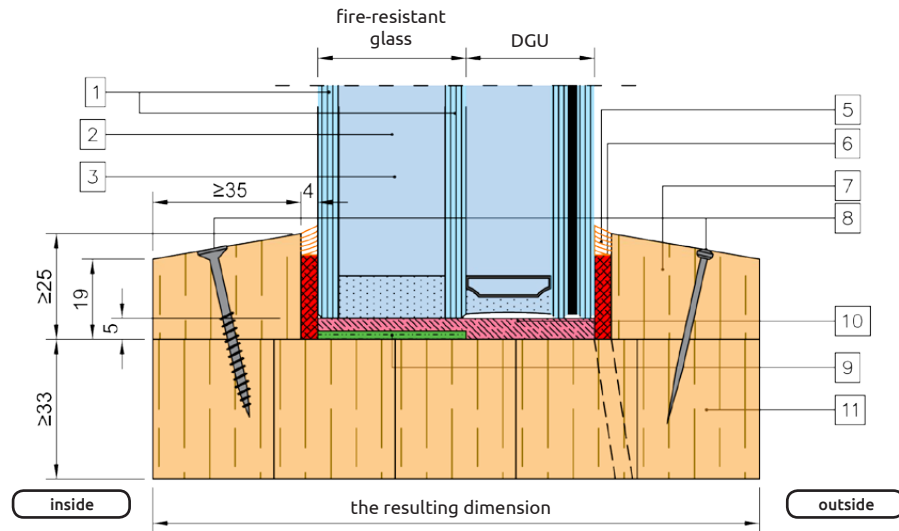

### POLFLAM EI 90 (35/37 mm) DGU

#### Partition wall

#### max. glass dimensions

1800 mm x 4200 mm ( $A_{max} = 6,35 \text{ m}^2$ ) - portrait

3600 mm x 1800 mm ( $A_{max} = 5,45 \text{ m}^2$ ) - landscape

reference document: DMT-DO-61-201

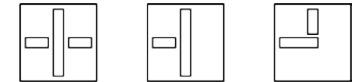

|    |   |
|----|---|
| 1* | thermally toughened glass $\geq 5$ mm thickness<br>thermally toughened patterned glass $\geq 6$ mm thickness<br>(individual panes can be tinted, coated, surface treated) |
| 2  | hydrogel interlayer $\geq 25$ mm thickness  |
| 3  | spacer $8 \div 20$ mm thickness   |
| 4  | glass $\geq 4$ mm thickness:<br>- float;<br>- thermally toughened glass (ESG);<br>- laminated glass (VSG);<br>(individual panes can be tinted, coated, surface treated)   |
| 5  | silicon Dowsil 791  |
| 6  | ceramic tape KERAFIX 2000 20 x 4 mm   |
| 7  | glazing bead $\geq 35$ mm x 25/19 mm timber $\geq 650$ kg/m <sup>3</sup>  |
| 8  | nail min. 16GA x 50 mm or screw $\varnothing 3,5$ x 50 mm<br>(20-40 mm from the corner and every 150 mm)  |
| 9  | intumescent tape KERAFIX FXL200 35 x 2 mm   |
| 10 | supporting block 5mm  |
| 11 | laminated or solid timber $\geq 650$ kg/m <sup>3</sup>  |

#### Allowed supported construction

rigid supporting construction min. 650 kg/m<sup>3</sup>; min. 180 mm thickness  
flexible supporting construction EI 90 min. 125 mm

\* above glass dimension over 1500 x 3000 mm or area over 4,5 m<sup>2</sup>  
glass pane pos.1 – min. 6 mm thickness

# POLFLAM EI 90 TGU

## Installation of POLFLAM glass in timber structures

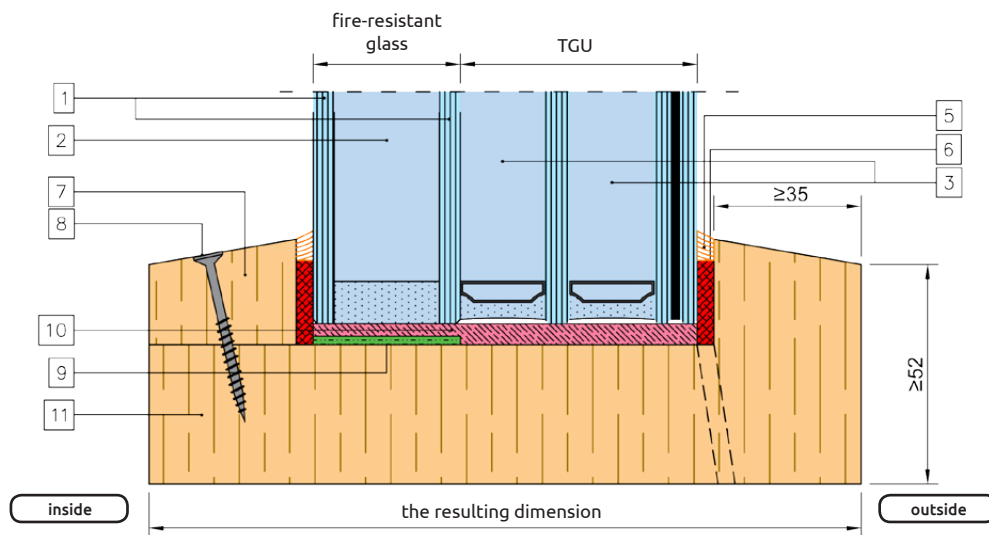
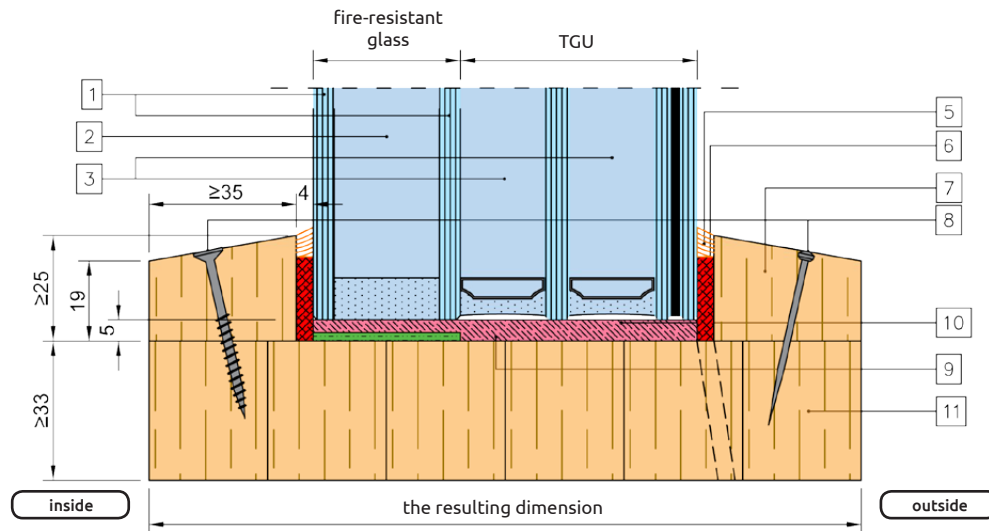

### POLFLAM EI 90 (35/37 mm) TGU

#### Partition wall

#### max. glass dimensions

1800 mm x 4200 mm ( $A_{max} = 6,35 \text{ m}^2$ ) - portrait

3600 mm x 1800 mm ( $A_{max} = 5,45 \text{ m}^2$ ) - landscape

reference document: DMT-DO-61-201

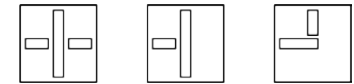

|    |   |
|----|---|
| 1* | thermally toughened glass $\geq 5$ mm thickness<br>thermally toughened patterned glass $\geq 6$ mm thickness<br>(individual panes can be tinted, coated, surface treated) |
| 2  | hydrogel interlayer $\geq 25$ mm thickness  |
| 3  | spacer $8 \div 20$ mm thickness   |
| 4  | glass $\geq 4$ mm thickness:<br>- float;<br>- thermally toughened glass (ESG);<br>- laminated glass (VSG);<br>(individual panes can be tinted, coated, surface treated)   |
| 5  | silicon Dowsil 791  |
| 6  | ceramic tape KERAFIX 2000 20 x 4 mm   |
| 7  | glazing bead $\geq 35$ mm x 25/19 mm timber $\geq 650$ kg/m <sup>3</sup>  |
| 8  | nail min. 16GA x 50 mm or screw $\varnothing 3,5$ x 50 mm<br>(20-40 mm from the corner and every 150 mm)  |
| 9  | intumescent tape KERAFIX FXL200 35 x 2 mm   |
| 10 | supporting block 5 mm   |
| 11 | laminated or solid timber $\geq 650$ kg/m <sup>3</sup>  |

#### Allowed supported construction

rigid supporting construction min. 650 kg/m<sup>3</sup>; min. 180 mm thickness  
flexible supporting construction EI 90 min. 125 mm

\* above glass dimension over 1500 x 3000 mm or area over 4,5 m<sup>2</sup>  
glass pane pos.1 – min. 6 mm thickness

## POLFLAM BR glass for frameless applications

POLFLAM BR glass allows you to create a transparent firewall without vertical posts (butt-joint glazing) with a height of up to 4200 mm and an unlimited length.

The frameless installation system makes it possible to supplement the partition with glazed fireproof doors or door without fire-resistance.



| POLFLAM BR glass                          | EI 30                            | EI 60     | EI 60 | EI 90     | EI 120*   |
|---|----------------------------------|-----------|-------|-----------|-----------|
| Thickness [mm]                            | 30                               | 35        | 38    | 45        | 50        |
| Weight [kg/m <sup>2</sup> ]               | 65                               | 69        | 75    | 82        | 90        |
| Light transmittance [Lt%]                 | 84,9                             | 84,5      | 75    | 83,8      | 81        |
| <b>Sound reduction R<sub>w</sub> [dB]</b> | <b>43</b>                        | <b>44</b> | 48    | <b>47</b> | <b>46</b> |
| Safety class                              | 1/B/1 (according to PN-EN 12600) |           |       |           |           |
| Operating temperature range               | -40°C / +50°C                    |           |       |           |           |
| Bent glass                                | yes                              |           |       |           |           |

\* Tests for resistance to fire are possible to conduct.

# POLFLAM BR EI 30

## Installation of POLFLAM BR glass in timber structures

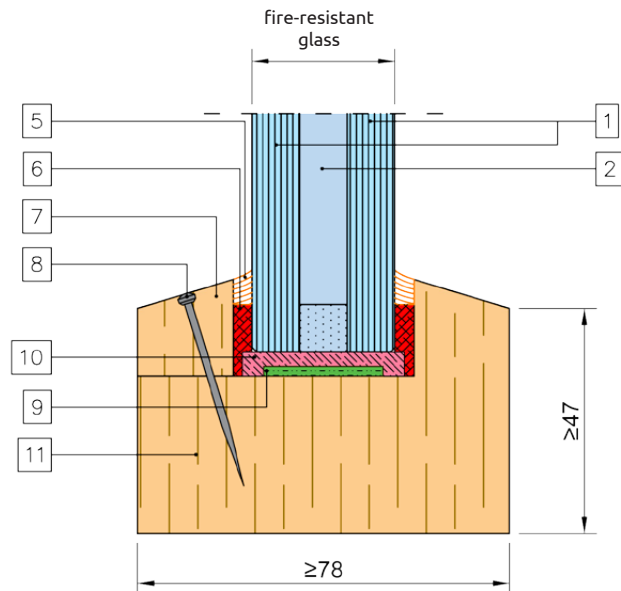
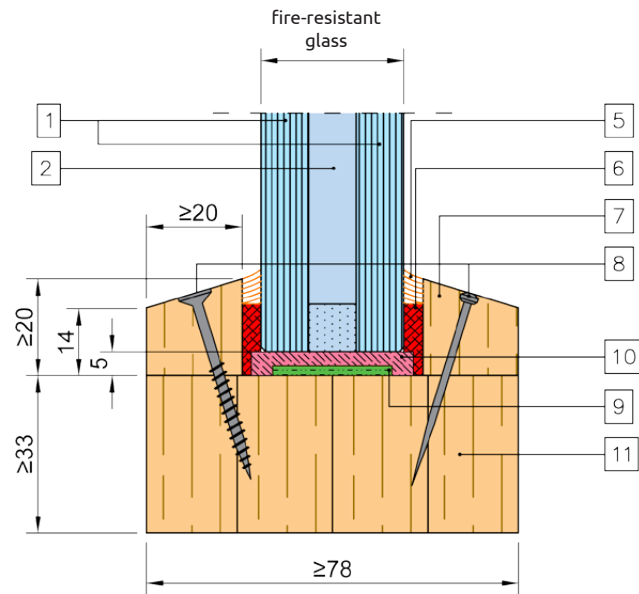

| POLFLAM BR EI 30 (30 mm)                      |  |
|---|--|
| Partition wall                                |  |
| max. glass dimensions                         | 2400 mm x 4200 mm ( $A_{max} = 8,47 \text{ m}^2$ ) - portrait  |
|   | 2400 mm x 4200 mm ( $A_{max} = 8,47 \text{ m}^2$ ) - landscape |
| reference document: Test Report DMT-DO-61-177 |  |

|    |   |
|----|---|
| 1  | thermally toughened glass $\geq 10$ mm thickness<br>(individual panes can be tinted, coated, surface treated) |
| 2  | hydrogel interlayer $\geq 10$ mm thickness  |
| 5  | silicon Dowsil 791  |
| 6  | ceramic tape KERAFIX 2000 15 x 4 mm   |
| 7  | glazing bead $\geq 20$ mm x 20/14 mm, timber $\geq 560 \text{ kg/m}^3$  |
| 8  | nail min. 16GA x 40 mm or screw $\text{Ø}3,5$ x 40 mm<br>(20-40 mm from the corner and every 200 mm)          |
| 9  | intumescent tape KERAFIX FXL200 20 x 2 mm   |
| 10 | supporting block 5 mm   |
| 11 | laminated or solid timber $\geq 560 \text{ kg/m}^3$   |

| Allowed supported construction  |
|---|
| rigid supporting construction min $650 \text{ kg/m}^3$ ; min 150 mm thickness<br>flexible supporting construction EI 30 min. 125 mm |

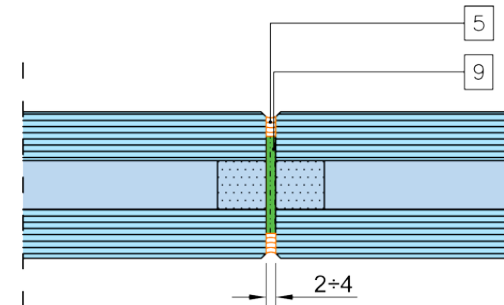

# POLFLAM BR EI 30

## Installation of POLFLAM BR glass with decorative wooden batten

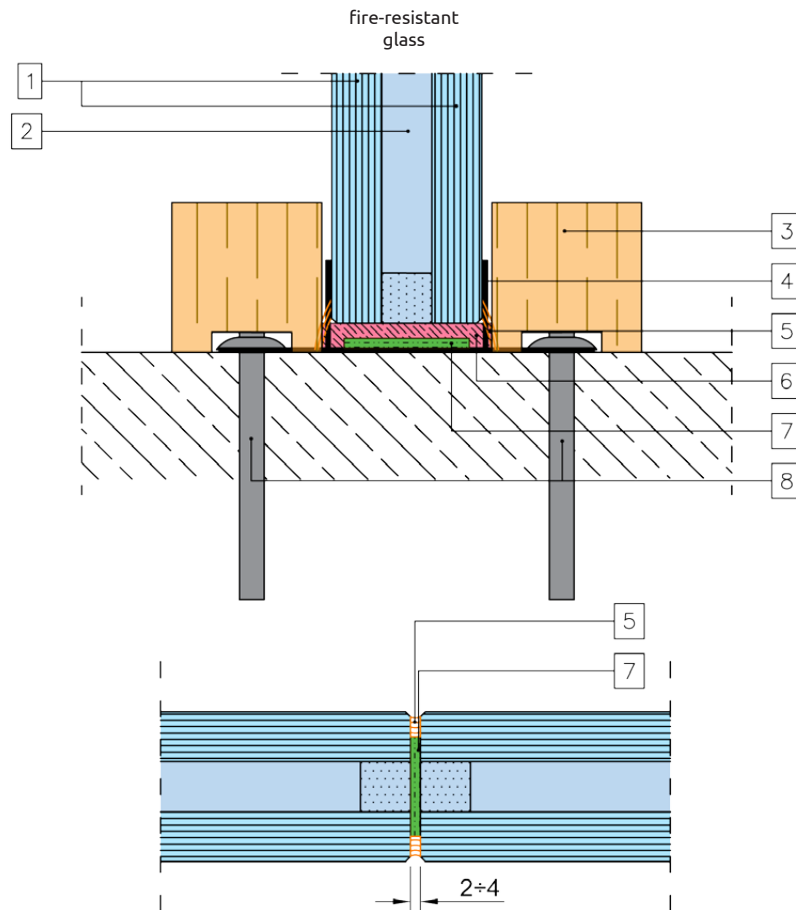

| POLFLAM BR EI 30 (30 mm)  |   |
|---|---|
| Partition wall  |   |
| max. glass dimensions   | 2200 mm x 4200 mm - portrait  |
|   | 2200 mm x 4200 mm - landscape   |
| reference document: LBO-731/15  |   |
| 1   | thermally toughened glass $\geq 10$ mm thickness<br>(individual panes can be tinted, coated, surface treated) |
| 2   | hydrogel interlayer $\geq 10$ mm thickness  |
| 3   | timber profile - $650 \text{ kg/m}^3$   |
| 4   | glass fixing bracket<br>(100 mm from the corner and every 400 mm)   |
| 5   | silicone:<br>1) PROMAT Systemglas<br>2) DOW Corning Firestop 700  |
| 6   | supporting block 5 mm   |
| 7   | intumescent tape:<br>1) PYROPLEX 2 x 22,2 mm<br>2) KERAFIX Flexpan 2 x 30 mm<br>3) PROMAT 2 x 30 mm           |
| 8   | hammer drive anchor $\text{\O}6 \times 50$ mm or screw WSPC $\text{\O}4.2 \times 40$ mm                       |
| Allowed supported construction  |   |
| wall of solid bricks, wall of concrete and reinforced concrete, wall of cellular bricks or perforated bricks, plasterboard wall |   |

# POLFLAM BR EI 30

## Installation of POLFLAM BR glass with decorative wooden batten

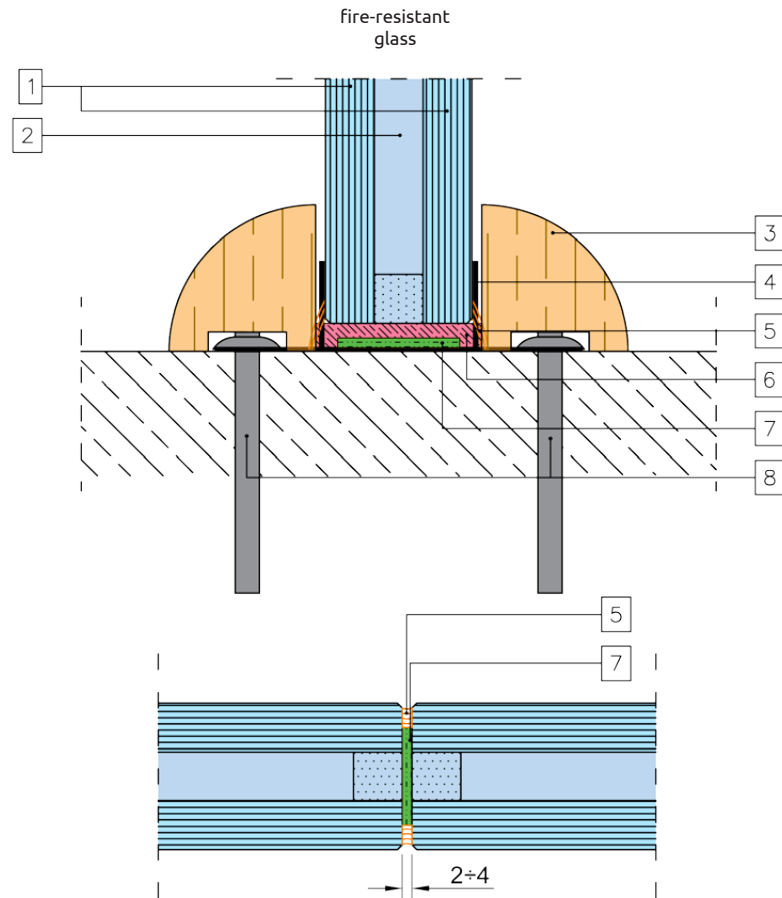

| POLFLAM BR EI 30 (30 mm)   |   |
|--|---|
| Partition wall   |   |
| <b>max. glass dimensions</b>   | 2200 mm x 4200 mm - portrait  |
|  | 2200 mm x 4200 mm - landscape   |
| reference document: LBO-731/15   |   |
| <b>1</b>   | thermally toughened glass $\geq 10$ mm thickness<br>(individual panes can be tinted, coated, surface treated) |
| <b>2</b>   | hydrogel interlayer $\geq 10$ mm thickness  |
| <b>3</b>   | timber profile - $650 \text{ kg/m}^3$   |
| <b>4</b>   | glass fixing bracket<br>(100 mm from the corner and every 400 mm)   |
| <b>5</b>   | silicone:<br>1) PROMAT Systemglas<br>2) DOW Corning Firestop 700  |
| <b>6</b>   | supporting block 5 mm   |
| <b>7</b>   | intumescent tape:<br>1) PYROPLEX 2 x 22,2 mm<br>2) KERAFIX Flexpan 2 x 30 mm<br>3) PROMAT 2 x 30 mm           |
| <b>8</b>   | hammer drive anchor $\text{\O}6 \times 50$ mm or screw WSPC $\text{\O}4.2 \times 40$ mm                       |
| Allowed supported construction   |   |
| wall of solid bricks, wall of concrete and reinforced concrete,<br>wall of cellular bricks or perforated bricks, plasterboard wall |   |



# POLFLAM BR EI 30

## Installation of POLFLAM BR glass with decorative wooden batten

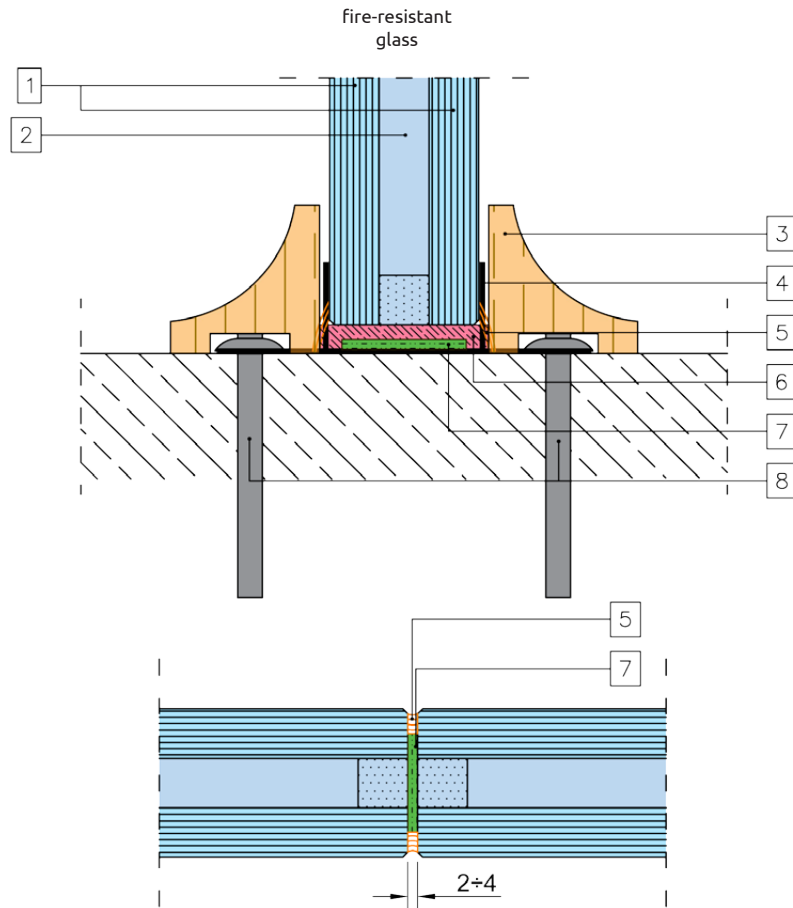

| POLFLAM BR EI 30 (30 mm)  |   |
|---|---|
| Partition wall  |   |
| max. glass dimensions   | 2200 mm x 4200 mm - portrait  |
|   | 2200 mm x 4200 mm - landscape   |
| reference document: LBO-731/15  |   |
| 1   | thermally toughened glass $\geq 10$ mm thickness<br>(individual panes can be tinted, coated, surface treated) |
| 2   | hydrogel interlayer $\geq 10$ mm thickness  |
| 3   | timber profile - $650 \text{ kg/m}^3$   |
| 4   | glass fixing bracket<br>(100 mm from the corner and every 400 mm)   |
| 5   | silicone:<br>1) PROMAT Systemglas<br>2) DOW Corning Firestop 700  |
| 6   | supporting block 5 mm   |
| 7   | intumescent tape:<br>1) PYROPLEX 2 x 22,2 mm<br>2) KERAFIX Flexpan 2 x 30 mm<br>3) PROMAT 2 x 30 mm           |
| 8   | hammer drive anchor $\text{\O}6 \times 50$ mm or screw WSPC $\text{\O}4.2 \times 40$ mm                       |
| Allowed supported construction  |   |
| wall of solid bricks, wall of concrete and reinforced concrete, wall of cellular bricks or perforated bricks, plasterboard wall |   |

# POLFLAM BR EI 60

## Installation of POLFLAM BR glass in timber structures

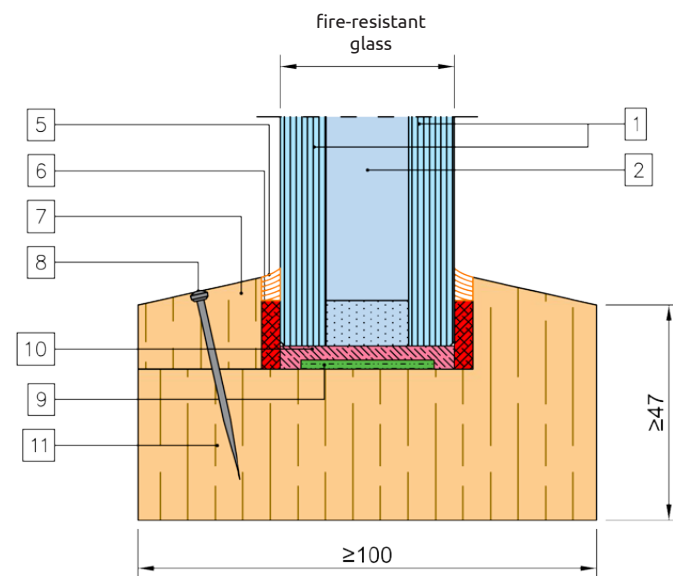
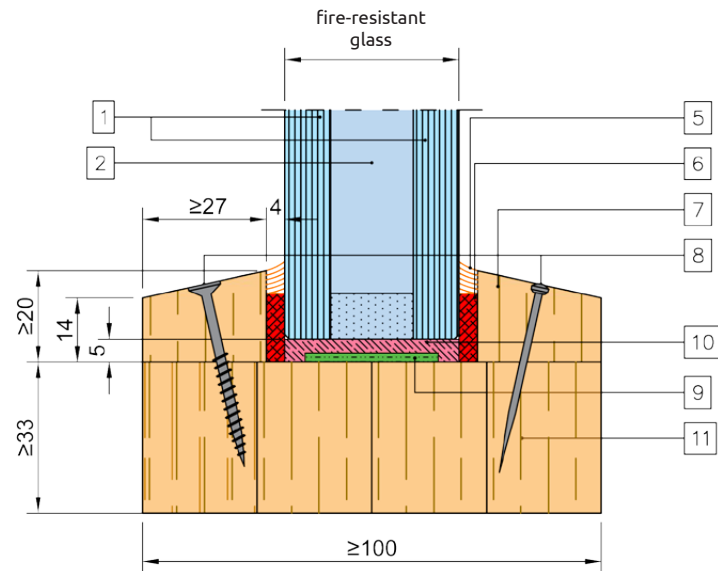

### POLFLAM BR EI 60 (38 mm)

#### Partition wall

#### max. glass dimensions

2200 mm x 4200 mm ( $A_{max} = 8,47 \text{ m}^2$ ) - portrait

2200 mm x 4200 mm ( $A_{max} = 8,47 \text{ m}^2$ ) - landscape

reference document: Test Report DMT-DO-61-198

|    |   |
|----|---|
| 1  | thermally toughened glass $\geq 10 \text{ mm}$ thickness<br>(individual panes can be tinted, coated, surface treated) |
| 2  | hydrogel interlayer $\geq 18 \text{ mm}$ thickness  |
| 5  | silicon Dowsil 791  |
| 6  | ceramic tape KERAFIX 2000 15 x 4 mm   |
| 7  | glazing bead $\geq 27 \text{ mm} \times 20/14 \text{ mm}$ timber $\geq 650 \text{ kg/m}^3$                            |
| 8  | nail min. 16GA x 40 mm or screw $\text{Ø}3,5 \times 40 \text{ mm}$<br>(20-40 mm from the corner and every 200 mm)     |
| 9  | intumescent tape KERAFIX FXL200 30 x 2 mm   |
| 10 | supporting block 5 mm   |
| 11 | laminated or solid timber profile $\geq 650 \text{ kg/m}^3$   |

#### Allowed supported construction

rigid supporting construction min  $550 \text{ kg/m}^3$ ; min 150 mm thickness  
flexible supporting construction EI 60 min. 125 mm

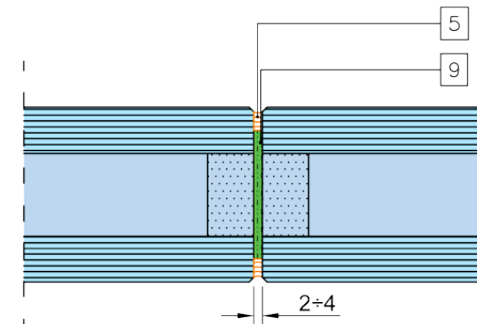

# POLFLAM BR EI 60

## Installation of POLFLAM BR glass with decorative wooden batten

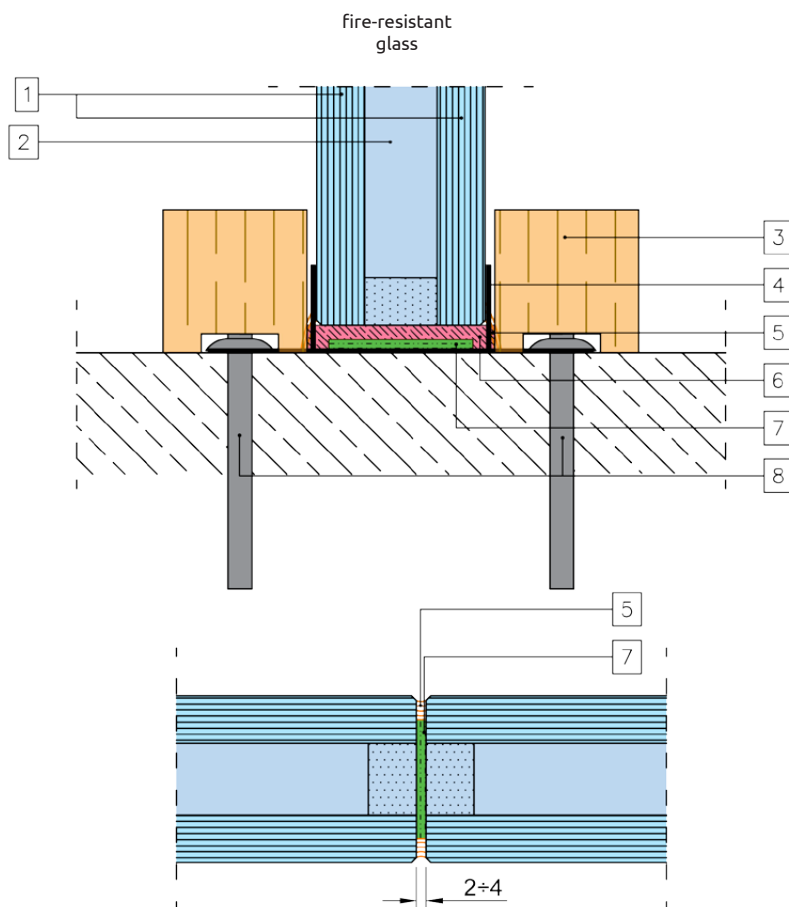

| POLFLAM BR EI 60 (35 mm)   |   |
|--|---|
| Partition wall   |   |
| <b>max. glass dimensions</b>   | 2200 mm x 3850 mm ( $A_{\max} = 7,70 \text{ m}^2$ ) - portrait  |
|  | 2200 mm x 3850 mm ( $A_{\max} = 7,70 \text{ m}^2$ ) - landscape   |
| reference document: LBO-1343/19  |   |
| <b>1</b>   | thermally toughened glass $\geq 10 \text{ mm}$ thickness<br>(individual panes can be tinted, coated, surface treated) |
| <b>2</b>   | hydrogel interlayer $\geq 15 \text{ mm}$ thickness  |
| <b>3</b>   | timber profile - $650 \text{ kg/m}^3$   |
| <b>4</b>   | glass fixing bracket<br>(100 mm from the corner and every 400 mm)   |
| <b>5</b>   | silicone:<br>1) PROMAT Systemglas<br>2) DOW Corning Firestop 700  |
| <b>6</b>   | supporting block 5 mm   |
| <b>7</b>   | intumescent tape:<br>1) PYROPLEX 2 x 22,2 mm<br>2) KERAFIX Flexpan 2 x 30 mm<br>3) PROMAT 2 x 30 mm                   |
| <b>8</b>   | hammer drive anchor $\text{\O}6 \times 50 \text{ mm}$ or screw WSPC $\text{\O}4.2 \times 40 \text{ mm}$               |
| Allowed supported construction   |   |
| wall of solid bricks, wall of concrete and reinforced concrete,<br>wall of cellular bricks or perforated bricks, plasterboard wall |   |

# POLFLAM BR EI 60

## Installation of POLFLAM BR glass with decorative wooden batten

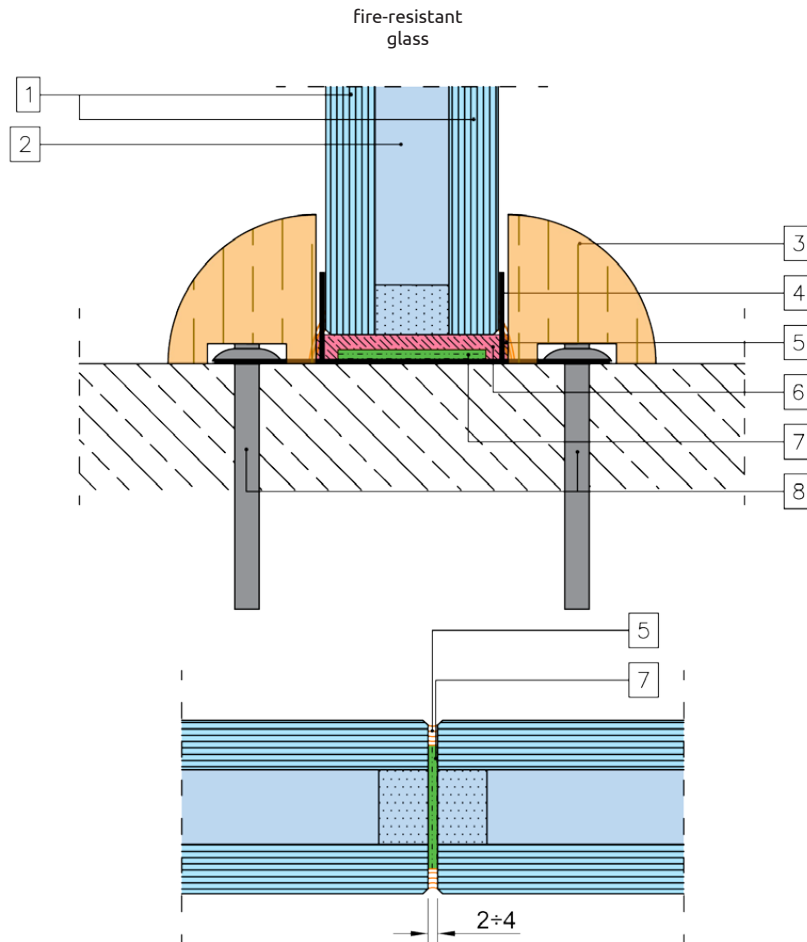

### POLFLAM BR EI 60 (35 mm)

#### Partition wall

#### max. glass dimensions

2200 mm x 3850 mm ( $A_{max} = 7,70 \text{ m}^2$ ) - portrait

2200 mm x 3850 mm ( $A_{max} = 7,70 \text{ m}^2$ ) - landscape

reference document: LBO-1343/19

|   |   |
|---|---|
| 1 | thermally toughened glass $\geq 10\text{mm}$ thickness<br>(individual panes can be tinted, coated, surface treated) |
| 2 | hydrogel interlayer $\geq 15 \text{ mm}$ thickness  |
| 3 | timber profile - $650 \text{ kg/m}^3$   |
| 4 | glass fixing bracket<br>(100 mm from the corner and every 400 mm)   |
| 5 | silicone:<br>1) PROMAT Systemglas<br>2) DOW Corning Firestop 700  |
| 6 | supporting block 5 mm   |
| 7 | intumescent tape:<br>1) PYROPLEX 2 x 22,2 mm<br>2) KERAFIX Flexpan 2 x 30 mm<br>3) PROMAT 2 x 30 mm                 |
| 8 | hammer drive anchor $\varnothing 6 \times 50 \text{ mm}$ or screw WSPC $\varnothing 4.2 \times 40\text{mm}$         |

#### Allowed supported construction

wall of solid bricks, wall of concrete and reinforced concrete,  
wall of cellular bricks or perforated bricks, plasterboard wall

# POLFLAM BR EI 60

## Installation of POLFLAM BR glass with decorative wooden batten

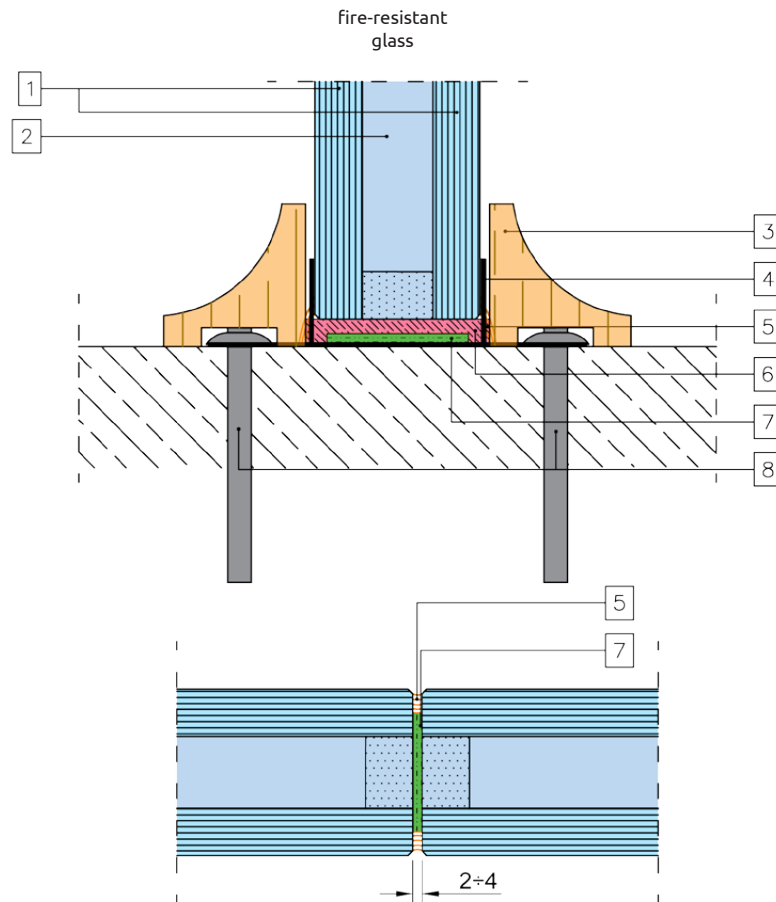

| POLFLAM BR EI 60 (35 mm)        |   |
|---------------------------------|---|
| Partition wall                  |   |
| max. glass dimensions           | 2200 mm x 3850 mm ( $A_{\max} = 7,70 \text{ m}^2$ ) - portrait  |
|                                 | 2200 mm x 3850 mm ( $A_{\max} = 7,70 \text{ m}^2$ ) - landscape |
| reference document: LBO-1343/19 |   |

|   |   |
|---|---|
| 1 | thermally toughened glass $\geq 10$ mm thickness<br>(individual panes can be tinted, coated, surface treated) |
| 2 | hydrogel interlayer $\geq 15$ mm thickness  |
| 3 | timber profile - $650 \text{ kg/m}^3$   |
| 4 | glass fixing bracket<br>(100 mm from the corner and every 400 mm)   |
| 5 | silicone:<br>1) PROMAT Systemglas<br>2) DOW Corning Firestop 700  |
| 6 | supporting block 5 mm   |
| 7 | intumescent tape:<br>1) PYROPLEX 2 x 22,2 mm<br>2) KERAFIX Flexpan 2 x 30 mm<br>3) PROMAT 2 x 30 mm           |
| 8 | hammer drive anchor $\varnothing 6 \times 50$ mm or screw WSPC $\varnothing 4.2 \times 40$ mm                 |

| Allowed supported construction   |
|--|
| wall of solid bricks, wall of concrete and reinforced concrete,<br>wall of cellular bricks or perforated bricks, plasterboard wall |

# POLFLAM BR EI 90

## Installation of POLFLAM BR glass in timber structures

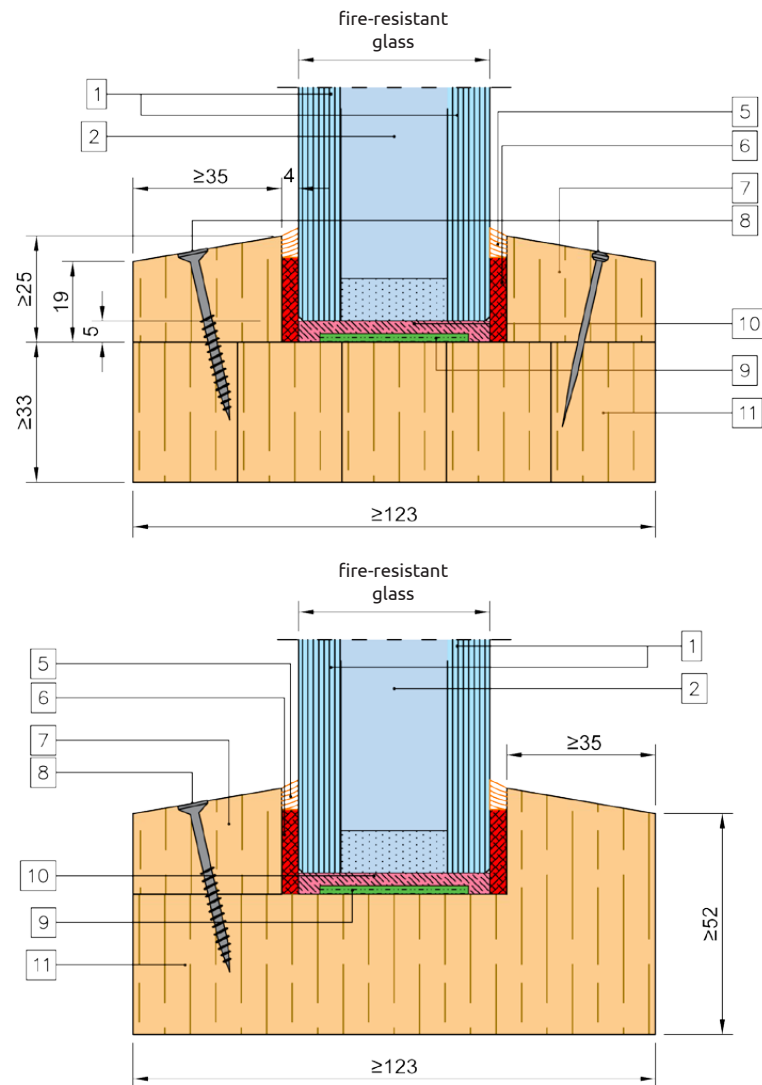

### POLFLAM BR EI 90 (45 mm)

#### Partition wall

|                              |  |
|------------------------------|--|
| <b>max. glass dimensions</b> | 2200 mm x 4200 mm ( $A_{max} = 8,47 \text{ m}^2$ ) - portrait  |
|                              | 2200 mm x 4200 mm ( $A_{max} = 8,47 \text{ m}^2$ ) - landscape |

reference document: DMT-DO-61-204

|           |   |
|-----------|---|
| <b>1</b>  | thermally toughened glass $\geq 10 \text{ mm}$ thickness<br>(individual panes can be tinted, coated, surface treated) |
| <b>2</b>  | hydrogel interlayer $\geq 25 \text{ mm}$ thickness  |
| <b>5</b>  | silicon Dowsil 791  |
| <b>6</b>  | ceramic tape KERAFIX 2000 20 x 4 mm   |
| <b>7</b>  | glazing bead $\geq 35 \text{ mm} \times 25/19 \text{ mm}$ timber $\geq 650 \text{ kg/m}^3$                            |
| <b>8</b>  | nail min. 16GA x 40 mm or screw $\text{Ø}3,5 \times 40 \text{ mm}$<br>(20-40 mm from the corner and every 200 mm)     |
| <b>9</b>  | intumescent tape KERAFIX FXL200 35 x 2 mm   |
| <b>10</b> | supporting block 5 mm   |
| <b>11</b> | laminated or solid timber profile $\geq 650 \text{ kg/m}^3$   |

#### Allowed supported construction

rigid supporting construction min.  $650 \text{ kg/m}^3$ ; min. 180 mm thickness  
flexible supporting construction EI 90 min. 125 mm

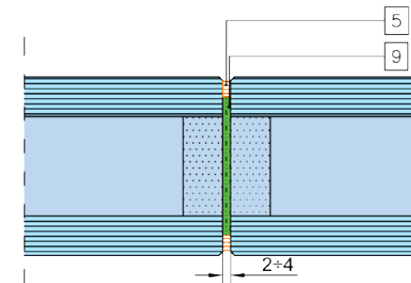



INTERIORS



WINDOWS  
AND DOORS

**POLFLAM**<sup>®</sup>  
FIRE RESISTANT GLASS

POLFLAM sp. z o.o.  
ul. Solidarności 1, Runów  
05-504 Złotokłos, Poland  
Phone: +48 22 726 92 17  
E-mail: [info@polflam.com](mailto:info@polflam.com),  
[export@polflam.com](mailto:export@polflam.com)  
[www.polflam.com](http://www.polflam.com)